

SCHOTT® E-Compressor Terminals

Our precision designs enable high power transmission and prevent refrigerant leakage

Product Information

Glass-to-metal sealed compressor terminals enable the transfer of large amounts of energy from the engine to the air conditioning compressor in electric and hybrid electric vehicles. These hermetically-sealed compressor terminals also help prevent leakage of the refrigerant.

Application

SCHOTT compressor terminals are suited for application in the air conditioning systems of electric vehicles (EV), hybrid electric vehicles (HEV), plug-in hybrid vehicles (PHEV), electrically-powered trucks and buses, high-speed rail, and server stations.



Electric vehicle

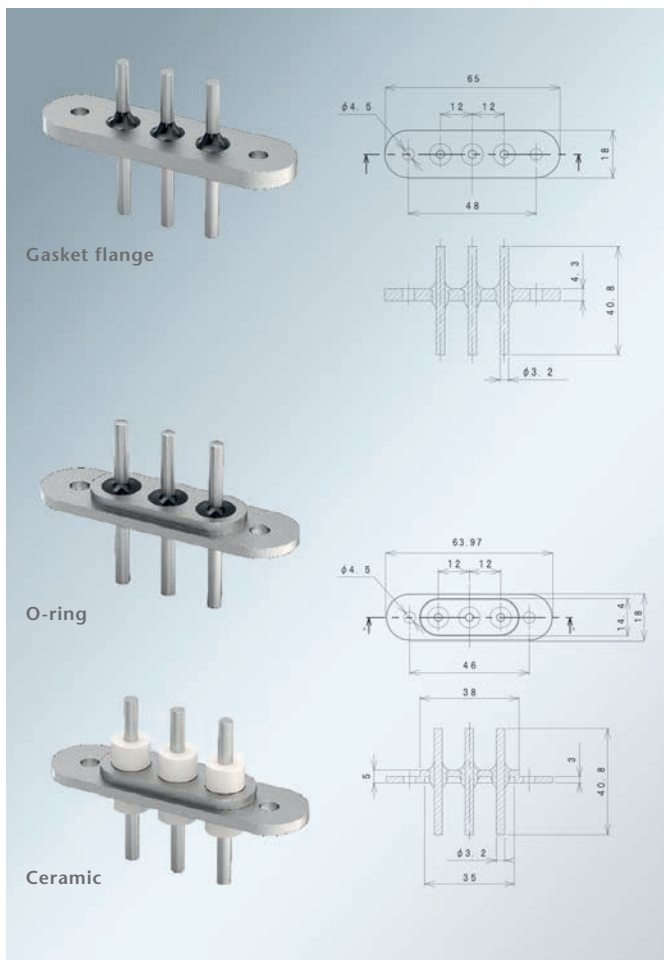

Advantages

Our cutting-edge designs help meet and exceed the demanding specifications of automotive applications

- Copper core pin designs are capable of transferring high amounts of power: up to a maximum of 35A.
- Non-ceramic designs ensure high insulation levels.
- Terminals can be made with silicone rubber, including UL94 V-0 for high-ignition point requirements.
- Flexible installation methods are available, such as O-ring and gasket flange variations.
- Highly reliable glass-to-metal seals can withstand harsh environmental conditions such as high heat and humidity for many years.

Custom designs and precision machining enable SCHOTT compressor terminals to meet even your most stringent requirements:

- Control of the base surface roughness:
Ra 1.6~3.2, Rz 12.5 ~
- Top of pin: R = 0.2, Pin pitch: $\varphi 0.5$ ~
- Intersection: ± 0.1

Why compressor terminals from SCHOTT?

- More than 50 years of experience in production of household and commercial compressor terminals.
- Customization according to individual requirements.
- At SCHOTT, we are happy to provide you with technical analysis (such as simulations of temperature and mechanical stress) to support your installation process.

SCHOTT Japan Corporation
3-1 Nichiden, Minakuchi-cho,
Koka-shi, Shiga 528-0034
Japan
Phone: +81 (0) 748-63-6638
Fax: +81 (0) 748-63-2371
comp.sjc@schott.com

www.schott.com/ep-japan

SCHOTT
glass made of ideas

SCHOTT® 电动车压缩机端子

我们高精密的产品设计，帮您实现大电流传输

产品信息

通常，通过玻璃-金属密封端子将大电流从发动机导入空调压缩机内部，使得电动汽车空调系统正常运作。同时，该密封端子还可以防止制冷剂泄漏。

应用

SCHOTT压缩机端子适用于各种新能源交通工具的空调系统。例如，电动汽车（EV）、混合动力汽车（HEV / PHEV）、电动客车、电动货车、高铁以及电动车充电站等。



电动汽车

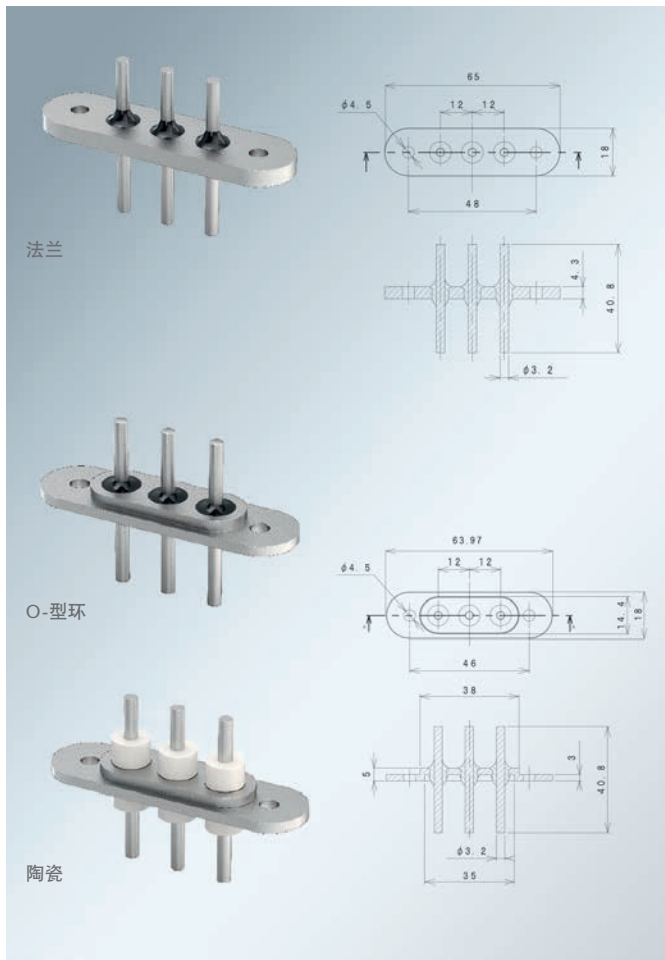

优势

尖端灵活的设计，符合甚至超出汽车领域各种高技术规格标准

- 铜芯针设计，实现高达35A的大电流传输。
- 无陶瓷设计，也可达到高绝缘效果。
- 可提供硅橡胶端子。UL94 V-0高燃点橡胶的使用，满足UL认证标准。
- 多种安装方式。例如：O型环及法兰等。
- 高可靠性能的玻璃-金属密封端子，可承受各种严苛的环境条件。例如：常年高湿高温等。

精密加工和定制设计，确保SCHOTT端子满足最高品质要求：

- 基座表面粗糙度控制: Ra 1.6~3.2, Rz 12.5 ~
- 针顶部: R = 0.2, 针间距: $\varphi 0.5$ ~
- 公差管理: ± 0.1

为什么使用SCHOTT压缩机端子?

- 在家用和商用压缩机端子领域，我们拥有长达50多年丰富的专业生产经验。
- 可客户定制。
- 在SCHOTT，我们为您提供全方位的技术支持（例如：温度和机械应力模拟分析等），帮助您成功完成端子安装等工序。

肖特（上海）精密材料和设备国际贸易有限公司

中国上海市虹梅路1801号
凯科国际大厦301室
邮编: 200233
电话: +86-21 3367 8000
传真: +86-21 3367 8080
info.china@schott.com

www.schott.com/epackaging/chinese

SCHOTT
glass made of ideas