

# SCHOTT PYRAN<sup>®</sup>

Special glass for integrity fire resistant glazing.



**SCHOTT**  
glass made of ideas



*Professional expertise paired with service and technical knowledge of the industry are qualities that are highly valued at SCHOTT Technical Glass Solutions GmbH.*

## Where visions meet, the future begins.

### **SCHOTT – a highly dynamic group of technology companies**

The SCHOTT Group operates worldwide, developing, manufacturing and delivering specialised materials, components and systems. The principal objective for SCHOTT products is to improve living and working conditions now and into the future.

The subsidiary SCHOTT Technical Glass Solutions GmbH is one of the leading international manufacturers of fire resistant glazing. Known for its PYRAN® and PYRANOVA® brands, SCHOTT offers specialised glass for reliable, structural, transparent fire protection to ensure safety, functionality and aesthetics all at the same time.

#### Contents

Products .....	Page 3
Systems .....	Page 7
Design and Variety.....	Page 9
Technical Data .....	Page 11

# Maximum safety with PYRAN®.

## It even protects the space for your ideas.

**SCHOTT PYRAN® – the original, made of borosilicate glass**

Borosilicate glass is the base material for the entire PYRAN® family of fire resistant glazing products. The standard PYRAN® design consists of a monolithic borosilicate glass, refined by thermal tempering and manufactured in a **Microfloat facility, the only one of its kind in the world**. This unique combination of **borosilicate glass and the float process** results in a specialised glass with outstanding characteristics.

As component parts in a wide variety of end-products, the versatile PYRAN® range of products has a long record of proven performance in fire resistant glazing that meets the requirements of fire resistance classes E 30 to E 120. For example, PYRAN® has shown impressive results in the Coeur Défense twin towers in Paris, the Red Bull hangar in Salzburg and the Mercedes Benz museum in Stuttgart. In these and in many other structures, PYRAN® offers multi-functionality and pleasing aesthetics while guaranteeing safety.

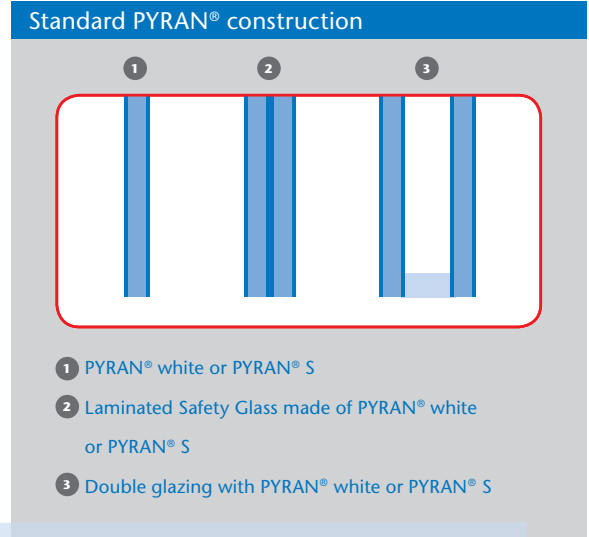

*With its wide variety of designs, PYRAN® can be used for interior and exterior applications.*

### Fire resistance categories for particular protection specifications

According to EN Standard 13501-2, fire resistant glazing is classified using the following combinations of letters and numbers:

● E: provides a physical barrier against flames, hot gases and smoke.

● EI: provides a physical barrier against flames, hot gases and smoke as well as thermal isolation.

● EW: provides a physical barrier against flames, hot gases and smoke and reduces heat radiation.

*PYRAN® meets the requirements for fire resistance category E. It provides a physical barrier against flames, hot gases and smoke.*

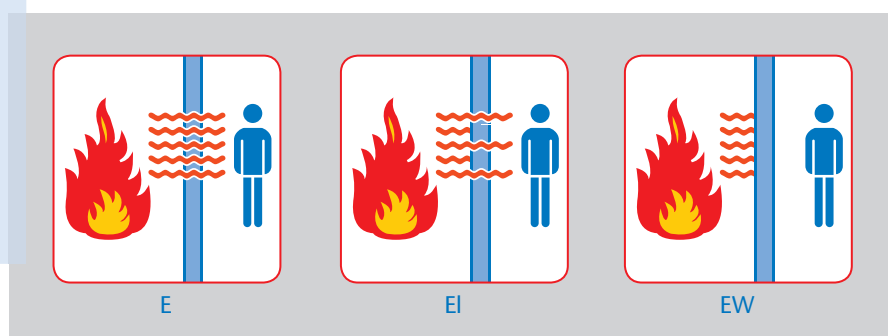

## Function

Fire resistant glazing with PYRAN® counteracts the spread of fire, hot gases and smoke. Even under high thermal loads, the glazing stays transparent, ensuring that the burning building can be safely evacuated.

PYRAN® fire resistant glazing made of borosilicate is far superior to conventional safety glasses with a soda-lime composition.

- High ability to withstand temperature differentials: in comparison, tempered borosilicate glass can better withstand temperature differentials and can be glazed with normal edge cover (15±2 mm).
- Higher softening temperature: because the glass is self-supporting for more than 30 minutes, large panes and simple frame construction are now possible.

- Higher viscosity: the glass flow rate is low due to the high viscosity and durability of borosilicate glass, so with more edge cover, greater fire resistance times in excess of 90 minutes can be achieved.
- NiS crystals do not form: due to the chemical composition of borosilicate glass, nickel sulphide crystals cannot form. A spontaneous glass fracture due to embedded NiS crystals cannot happen with PYRAN®.

## Areas of application

PYRAN® can be used for all applications which have high safety requirements but that demand original design as well.

With 25 years of extensive experience in the fire protection industry, SCHOTT Technical Glass Solutions GmbH is both proficient and innovative. In co-operation with system partners, SCHOTT develops designs with PYRAN® that have been internationally approved and are ideally suited for:

- Facades
- Partition walls
- Skylights and rooflights
- Doors
- Roofs
- Smoke screens
- Lift glazing

Fire resistance classification	Framing material/system					
	Steel	Timber	Aluminium	Plasterboard construction system	Butt joint	Point-fixed
E 30	●	●	●	●	●	●
E 60	●	●		●	●	
E 90	●			●		
E 120	●					

More detailed information is available in the respective country-specific certification reports and permits.

# Wide scope of applications and specific solutions

## The PYRAN® product group offers both

### PYRAN® S

Among the entire range of SCHOTT fire resistant glazing products, PYRAN® S offers the greatest multi-functionality. PYRAN® S is a monolithic, thermally tempered borosilicate safety glass according to DIN EN Standard 13024-1.

PYRAN® S is a regulated building material and can be used for single or double glazing without conducting the heat soak test.

Thus PYRAN® S offers yet another advantage in terms of safety and dependability.

As a component in a wide variety of end products, it has a long record of proven performance in fire resistant glazing that meets the requirements of fire resistance classes E 30 to E 120, due to its outstanding optical and mechanical characteristics.



The interplay of innovative system solutions and creative design freedom awakens the full potential of PYRAN® S.

PYRAN® S characteristics include

- high transmission in the visible and ultraviolet spectral ranges
- brilliant optics, ensuring natural, pure colour reproduction.

PYRAN® S demonstrates extreme durability against

- aggressive environmental atmospheric attack
- exposure to UV radiation
- abrasive chemical solutions

*PYRAN® S meets the requirements for single-pane safety glass according to DIN 1249-12 and/or DIN EN 13024-1. If PYRAN® S is broken under heavy impact it shatters into small and relatively harmless granules, conforming to regulation for accident insurance and for health and safety at work.*



## PYRAN® white

PYRAN® white offers a real alternative when customised solutions are needed for specific structural conditions. PYRAN® white is a monolithic, thermally annealed glass, manufactured from borosilicate glass according to DIN EN 1748-1.

Due to the annealing process PYRAN® white has a bending strength of 70 N/mm<sup>2</sup>, comparable with annealed soda-lime glass according to DIN EN 18631. Because of its special composition, however, PYRAN® white's ability to withstand temperature change is significantly higher.

As a component of fire resistant glazing that meets the requirements for fire resistance class E 30, PYRAN® white's price range in relation to its performance is especially appealing.

PYRAN® white can be used whenever technical fire protection requirements have to be brought into line with cost-effective solutions.

### Light transmission

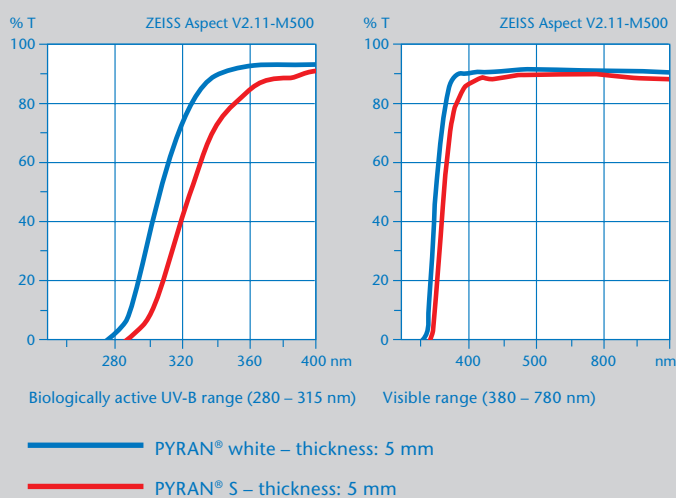

*PYRAN® white also has outstanding transmission in the visible and the biologically active UV-B radiation spectral ranges (280 – 315 nm).*

## PYRAN® G

While flat glass panes arranged in a circular formation create an interrupted appearance, curved PYRAN® G components facilitate a clear, complete visual outlook.

PYRAN® G is a monolithic, thermally annealed borosilicate glass. In a forming process, PYRAN® G takes on its typical, cylindrical shape.

Used in fire resistant glazing that meets the requirements of fire resistance class E 30, PYRAN® G has an outstanding transparency combined with visually stunning design.



*PYRAN® G curved fire resistant glazing provides both safety and aesthetic properties, as in the Fraunhofer Haus in Munich.*

## PYRAN® S-AR

PYRAN® S-AR simultaneously carries out several important functions. It provides clear visibility due to low residual reflection, and in case of fire, it offers additional protection of up to 2 hours.

PYRAN® S-AR is a monolithic and thermally hardened borosilicate glass. Manufactured in an immersion process, it is anti-reflecting on both sides. The glass is coated with a hard, weather-resistant and multi-layered interference system, which contains additional metal oxides. As a result, a light reflection of 8% with uncoated glass can be reduced to 1% with coated borosilicate glass.

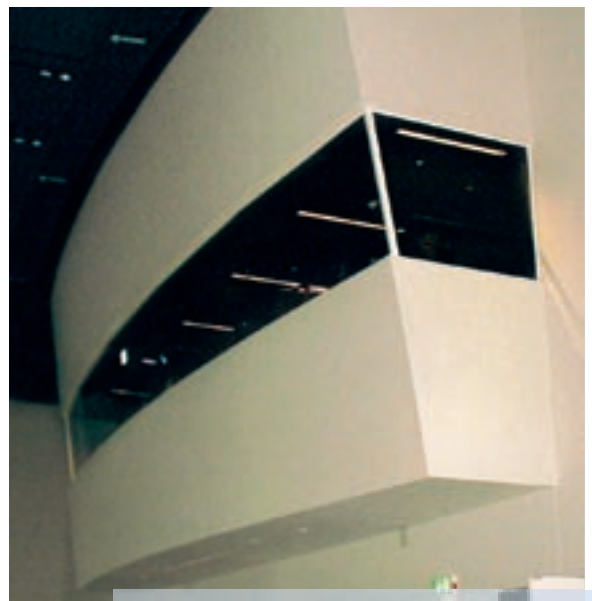

*Both visual and safety-related purposes can be served simultaneously with the special anti-reflection coatings on PYRAN® S glass, which is used for projection openings in cinemas or in display windows.*

Comparison of reflection: PYRAN® S-AR and normal, clear float glass

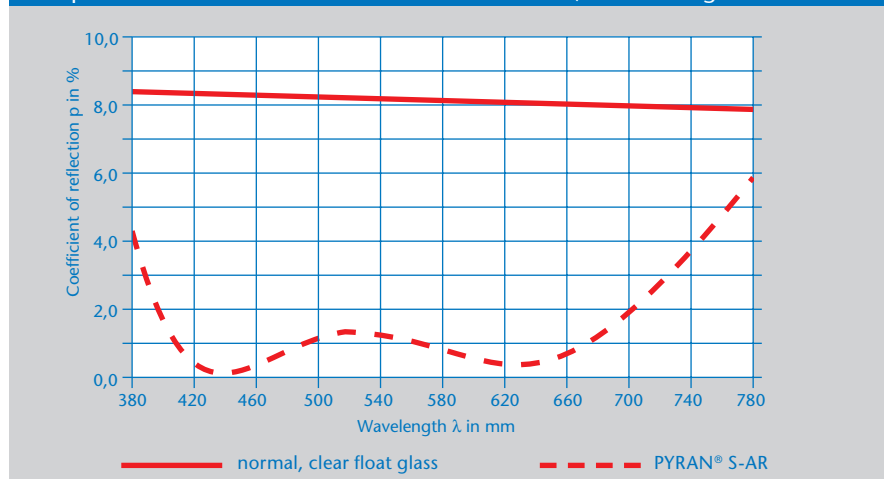

# Ideas come to life – with endless sheets of glass by SCHOTT.

**A clear view to your design creativity.**

## Endless design freedom with the PYRAN® S-SF butt joint system

PYRAN® S-SF fits effortlessly into demanding architectural designs. With a special silicone joint, the PYRAN® S-SF butt joint system joins the panes of glass without a frame.

This allows for the creation of light, smooth sheets of glass, almost endless, that ensure a clear view at all times without the disruption of vertical jamb profiles.

Ideal for applications where fire protection must be combined with maximum visibility and minimal visual interruption:

- + design freedom with large areas of glazing
- + the view takes in everything – no disruptive jambs
- + large panes – from floor to ceiling
- + endless sheets of glass
- + over 60 minutes of fire resistance



*PYRAN® S-SF butt joint system is also available as angled version.*

## Sectional drawing

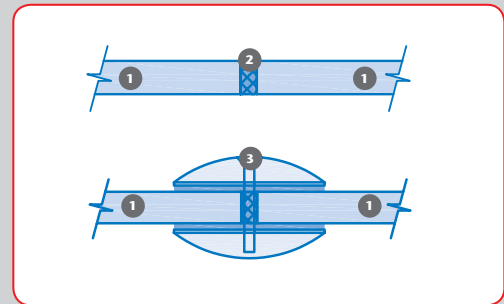

- 1 PYRAN® S
- 2 Fire resistant silicone; comes in black, grey, white, dark brown and olive brown
- 3 Connector\*

\*Depending on the specifications in the respective permit, each butt joint may require a connector to secure the panes in position.



**„With PYRAN® S-SF and PYRAN® S we were able to meet the legal requirements for fire protection in the renovation of the existing ‚Haus der Wirtschaft Baden-Württemberg‘ and the ‚Wirtschaftsministerium Baden-Württemberg‘, both of which are listed under a preservation order. We were able to create sophisticated solutions for both the technical, and above all, the formal aspects.“**

**Christoph Daniel Anstett, Architect**

## PYRAN® S-P

Systems that use PYRAN® S-P do not need frame constructions at all. This is the result of a perfect symbiosis of glass panes connected to each other by joints that are barely noticeable and point mounts and brackets that secure the glass panes to a strong, but light, supporting structure. Even under the most extreme conditions such as heavy loads created by wind pressure or suction, the panes remain permanently fixed in place, free of tension and without slippage.

PYRAN® S-P is ideal for smoke screen applications in heavy traffic areas such as atria, shopping centres and underground stations.



*Point-fixed systems with PYRAN® S-P offer light, strong and aesthetically pleasing fire protection solutions.*



*A frameless, point-supported glass facade was created for the Bluetower in St. Johann with SCHOTT fire resistant glazing. The connection of the double-glazed elements with PYRAN® S was achieved using purpose-built steel sections, which were attached with stainless steel point fittings at each intermediate floor.*

# Better safe than sorry. But for SCHOTT, that's just not good enough.

## More functionality with double glazing units

### A strong partnership – fire resistant glazing and functional glass

ISO PYRAN® double glazing units can be used whenever PYRAN® fire resistant glazing needs to fulfil other glass functions as well.



ISO PYRAN® makes extraordinary designs possible like the BMW-World in Munich.

*In combination with functional glasses for double-glazing construction, ISO PYRAN® meets additional demands in terms of aesthetics and energy-efficiency. ISO PYRAN® counterpanes can be custom-designed and shaped, offering advantages in the following categories:*

- + Sun protection (anti-glare)
- + Heat insulation
- + Sound insulation
- + Safety against falling or overhead obstacles
- + Design
- + Personal safety and property security
- + X-ray protection
- + Screening, with its integrated sunblind system.

#### Standard design ISO PYRAN® S / ISO PYRAN® S-D

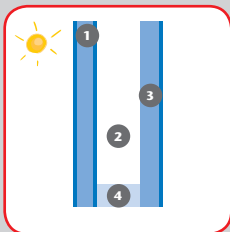

- 1 PYRAN® S pane,  $\geq 5$  mm thick
- 2 Space between the panes,  $\geq 8$  mm wide
- 3 Inner panes,  $\geq 4$  mm thick, can be tinted, printed and/or coated
- 4 Spacer, sheet steel profile

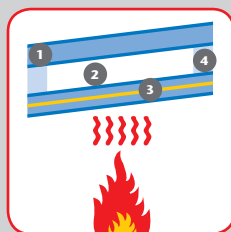

- 1 PYRAN® S pane,  $\geq 6$  mm thick
- 2 Space between the panes,  $\geq 8$  mm wide
- 3 Inner panes,  $\geq 6$  mm thick, laminated sheet glass (LSG), can be tinted, printed and/or coated
- 4 Spacer, sheet steel profile

#### Standard design ISO PYRAN® R

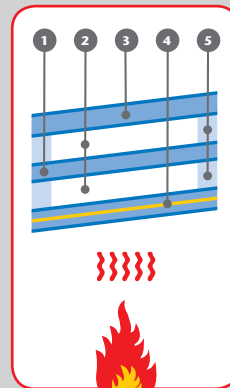

- 1 PYRAN® R middle pane,  $\geq 5$  mm thick
- 2 Space between the panes,  $\geq 8$  mm wide
- 3 Outer pane,  $\geq 6$  mm thick, float glass
- 4 Inner pane,  $\geq 6$  mm thick, laminated sheet glass (LSG), can be tinted, printed or coated
- 5 Spacer, sheet steel profile

*In ceilings, fire resistant glazing is used to prevent fire from jumping from floor to floor. Because these glasses are subject to particular loads, for overhead areas, the use of laminated sheet glass is required.*

## As changeable as a chameleon

ISO PYRAN®'s multi-functionality is also guaranteed in terms of design elements. Glasses with ornamentation, colours or patterns can be used as counterpanes in fire resistant double glazing products, turning them into real eye-catchers.

## Design with sand-blasting

Sand-blasting can be used to purposely modify the surface structure of PYRAN® S panes. A visually inconspicuous design is the result, the aesthetics of which are fully revealed with illumination. This process does not diminish the durability or the performance of these functional glasses. When added to the glass surface, extremely thin and nearly invisible functional layers protect it from corrosion, dirt and other contamination.

## Design with screen printing

Entire surfaces of PYRAN® S can be printed without restriction on the degree of printing, so that characteristics such as glass transparency, energy flow and/or glare protection can be individually managed.

With rich colour nuances and an abundance of patterns, screen printing opens up a wealth of new design possibilities for fire resistant glazing. Depending on the colours chosen, either screen printing or a roller process is used to apply them to the glass surface. In the subsequent thermal tempering process, the colours are burned into the glass surface. The resulting glasses are as colourfast, abrasion-resistant, scratch-resistant and weather-proof as unprocessed glass surfaces, and require just the same low maintenance.

## Easy, convenient sun protection and screening

Easy to use, electrically operated foil blinds and electric or manually operated Venetian blinds fit exactly into the space between panes of ISO PYRAN®. They are easy to use and can be controlled and positioned as desired. These systems offer dependable sun protection, screening and glare protection, specific control over ambient light, energy savings and comfort.

## Meets every demand

The innovations from SCHOTT open up completely new perspectives regarding the creative interplay among function, aesthetics and design. Fire resistant glazing from SCHOTT Technical Glass Solutions GmbH meets the demands of modern architecture and makes it possible to ensure safety and construct protective barriers that are user-friendly and nearly invisible.



*Evelina Children's Hospital, London: Sandblasted PYRAN® S offers privacy as well as reassuring safety.*



*Mercedes-Benz Museum Stuttgart: not just the elaborately designed fire resistant glazing with the two-colour screen-printed pattern and the PYRAN® S-SF butt joint glazing – almost everything at the Mercedes-Benz Museum is unique.*

# For the clear perspective you're accustomed to: PYRAN®. Numbers and facts.

## Technical data

Glass type	Fire resistance time according to EN 13501	Glass thickness [mm]	Weight [kg/m <sup>2</sup> ]	Light transmission [%]	Ug-value [k/Wm <sup>2</sup> ]	g-value [%]	Sound insulation value [dB]	Max. manufacturing size [mm]
PYRAN® white	E 30	5	11,1	92,6	5,8	91	30	1600 x 3000

PYRAN® S	E 30 – 120	5	11,4	92	5,8	90	30	1650 x 3100
		6	13,7	92			31	
		8	18,2	92			32	1800 x 3600
		10	22,8	91			33	
		12	27,4	91			34	

Min. manufacturing size W x H [mm]	130 x 270
------------------------------------	-----------

Other designs and possible combinations can be found in the technical data or will be provided by request. The maximum size tested can be found in the applicable national approval.

If you have further questions about special glass from SCHOTT for fire resistant glazing, use our service hotline!

 **+49 (0)3641/681-4666**

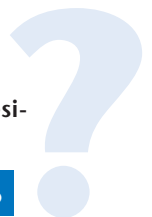

**SCHOTT Technical Glass  
Solutions GmbH**  
Otto-Schott-Straße 13  
07745 Jena  
Germany  
Phone: +49 (0)3641/681-4666  
Fax: +49 (0)3641/28889311  
E-Mail: [info.pyran@schott.com](mailto:info.pyran@schott.com)  
[www.schott.com/pyran](http://www.schott.com/pyran)

**SCHOTT**  
glass made of ideas