

Photovoltaics

2 Sunny Times

Otto Schott Research Award

6 Milestones for Glass Science

Jena

9 German Chancellor Visits Schott

Astronomy

10 From the Simple Tube to the High-tech Telescope

Electronic Packaging

14 Strong Partners for a Strong Business

Shop Window Design

17 A Commercial on Glass

Metrology

18 Precise Testing Bodies

Household Appliance Industry

20 Good Ideas Implemented Quickly

Art With Light Effects

23 A World Made of Small Lights

Technical Glass Beads

24 Completely Perfect

Functional Glasses

26 Functional Elegance

Bathroom Fixtures

28 More Glass for the Bathroom

Prisma

30 Short Reports from the Schott Group; Preview; In the Next Issue

Anne Hardy

Science Journalist
Frankfurt, Germany

Sunny

The acquisition of America's Applied Power Corporation provides Schott with a ticket to a market with good long-term growth potential.

The goals are ambitious. By the year 2010, Schott aims to be the number one or number two player among suppliers of photovoltaic systems. The new Schott subsidiary has more than 20 years experience in the market, which can now be combined with the parent company's well-developed global sales network.

Why photovoltaics? This is an obvious question for those who know Schott as a manufacturer of special glass. "The photovoltaics market is growing at a rate of 20 to 25 percent a year," said photovoltaics segment manager Michael Harre. "This offers Schott good opportunities for development. For a start, photovoltaics has a lot to do with glass and glass handling. This new business is also an excellent fit with our Vision 2010, the core purpose

of which defines that we will improve how people live and work through expert solutions. And finally, photovoltaics is now a global market. Schott's international network puts us in a very good position to tackle the market."

Specialist in Photovoltaic Arrays

Schott Applied Power Corporation (SAPC) is already a leading supplier of photovoltaic systems in the United States. As a system integrator, the company develops and markets individual complete systems. The components, such as photovoltaic modules, batteries and DC-AC inverters, are purchased from various suppliers. From the earliest years of its existence, SAPC has belonged to a small group of companies selected by the US government to carry out publicly-funded photovoltaic projects. Today the Schott subsidiary is known for its many years of experience but also for its broad range of products and services. Larger past projects include the electrification of rural areas in Brazil, turnkey systems for the operation of telecommunications systems, the conversion of solar energy into electricity for buildings connected to a municipal power supply and



Times

consumer goods applications (e.g. for private mobile homes and cabin cruisers).

Solar Power – makes Economic Sense

The economic efficiency of photovoltaic arrays is often underestimated. "One of the reasons is that we generally only think of state subsidized projects such as the '100,000 Roof Program' in Germany," says Harre. In fact it is hard to conceive the on-grid share (connected to public utilities) of the market without subsidies. In so doing, people overlook the many off-grid applications. These arrays actually are

World Energy Consumption by 2060

Source Shell AG

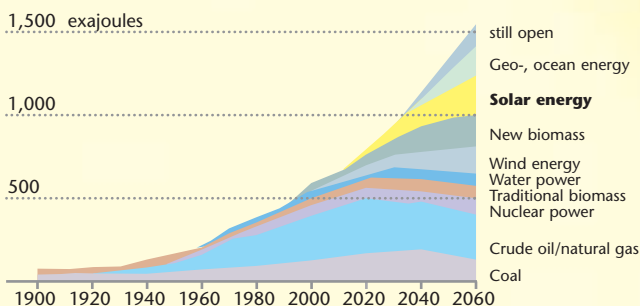

The Sun Supplies Free Energy

The sun is a giant fusion reactor with a diameter more than 100 times that of the Earth. For more than four billion years it has been supplying the Earth with free energy from a distance of around 150 million kilometers. At the center of the sun, a fusion process takes place at very high temperatures in which four hydrogen nuclei unite and form one helium nucleus. Each second some 600 tonnes of hydrogen are burned to form helium and thereby release a portion of their mass as radiation. In this way the sun loses almost one percent of its mass over a period of 1.24 billion years. Although only a two billionth part of the total solar energy emitted reaches the Earth, this tiny proportion has been enough to provide life on Earth with energy and to sustain life cycles. Experts calculate that the solar energy that falls on the surface of the Earth is around 2700 times greater than the world-wide primary energy requirement. Taking into consideration the enormous amount of solar radiation available in comparison to the primary energy requirement, it would be technically possible to obtain all the world's energy from the sun.

(Source: www.solarenergie.de)



The US General Services Administration in Suitland, Maryland operates a 100 kW thin film pilot unit. In comparison with conventional photovoltaic systems equipped with silicon wafers, here glass substrates coated with thin films are used.



A grid-connected photovoltaic array at Alliant Energy in Winnebago, Minnesota. It can be used to bridge any supply shortfalls at peak times.

cheaper than the costs associated with connection to the grid. Examples include parking meters, emergency telephones and traffic signs on motorways, as well as telecommunications networks.

In a vast and thinly populated continent like Australia, photovoltaic generators are also used in telecommunications as they are considerably more durable than diesel generators. Solar powered generators usually have an operating guarantee of 25 years. "Two thirds of the photovoltaic market is also attractive from a purely economic

point of view", states Harre. This also guarantees companies operating in this business a certain degree of autonomy from political decisions. In the long term the trend is towards environmentally friendly energy. According to a study carried out by Shell, the climate protection target to significantly reduce carbon dioxide emissions can only be achieved by supplying half of the world's energy requirements with renewable energy by the year 2060.

A large market for photovoltaics is opening up in the structurally weak countries of the Third World. Here solar energy offers the only possibility of providing billions of people with

electricity for lighting, refrigeration and communications – and that without placing additional burden on the environment. This too is an important reason for Schott's commitment to photovoltaics. SAPC's experience in this area provides an excellent foundation. It has already carried out several projects in rural areas in Brazil, Mexico, India, Bolivia, Kenya and Sri Lanka.

Competence in Glass and Coating

From the technical point of view, Schott's expertise in the development, production and coating of glass make the photovoltaics business very attractive. Although the conventional silicon wafer technology will continue to dominate the market in the foreseeable future, in the long term, experts see a trend towards thin film solar modules which promise to be significantly less expensive to make. These consist of glass or metal panels several square meters in size, onto which a layer of semiconductor material only a few micrometers thick is applied. In this way large size solar cells can be produced quickly and with low material and energy usage. These cells still lack efficiency (approx. 8%) but research is currently concentrated on increasing this. The efficiency of screen printed solar cells is 12 to 15 percent. The thin film technology shows potential for good long term growth ■

The Weyerhouse Residence (Federal Way, Washington) has its own small power plant. A photovoltaic system is built into the roof in place of tiles and supplies the electricity required.

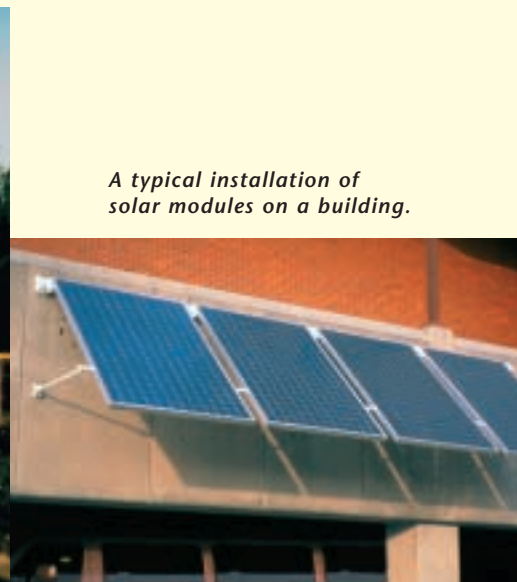

A typical installation of solar modules on a building.

Photovoltaics



Opportunities for structurally weak regions, seen here in Morocco where solar arrays supply electricity for water pumps.

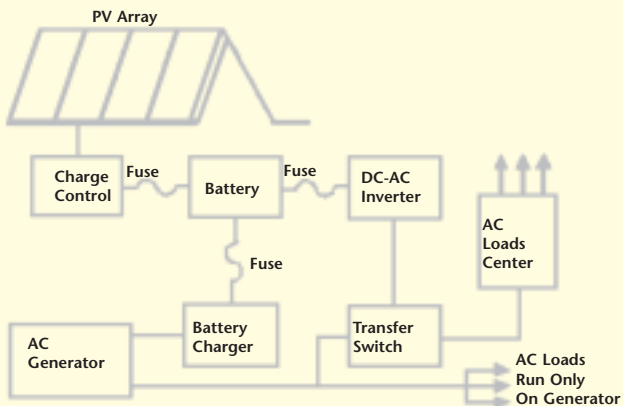

Photovoltaic systems: Turning Light into Power

The most important component in a photovoltaic array is the solar cell, where light is converted into electricity. About ten to 100 cells form a module. Depending on the electrical output required, several modules are coupled together into a solar generator. In this way arrays with capacities ranging from a few milliwatts to several megawatts can be set up. The costs incurred can be divided half and half between the photomodule and the coupling into an integrated system.



The SAPC Readypower Battery is a typical back-up system, which stores surplus solar electricity during the day and makes the energy available again when required – for example at night.



An environmentally friendly alternative to diesel generators: The Capitol Reef National Park in Utah uses photovoltaic modules to pump water from deep below ground.

