

"SENSUS" Sharpens the Senses

Its foot is larger, its neck a little longer and its body has been completely redesigned: After two years of intensive collaboration with the German Agricultural Association (DLG) and the German Wine Institute, Schott Zwiesel has just unveiled the new, official DIN wine tasting glass.

"Sensus" is the name given to the new creation, which was classified as suitable for the tasting of both red and white wines. So that sparkling wines can be tasted as well, the glass can be provided with a so-called effervescence point allowing a stream of bubbles to form.

The shape and size of a wine glass has a considerable influence on the overall sensory impression that one gets when tasting a wine. Several research studies have indicated that this perception intensifies as the height of the goblet increases and the diameter of its opening is reduced. From a total of nine prototypes, "Sensus" achieved the best results in the perception of the leading aromas. Other important criteria that were taken into account in the overall design were its handling and balance as well as the swinging and runoff behavior of the glass.

The pleasing appearance and high user-friendliness of the tasting glass should make it an instant favorite even outside professional circles – for example, with wine growers and traders. Last but not least, the hobby oenologist can also use this glass to "check up" on the experts' decision and then decide to award one's own wine a very personal quality seal ■

The new DIN wine tasting glass made by Schott Zwiesel convinces German wine experts.

Standardized Form

The new wine tasting glass made by Schott Zwiesel will replace the standardized types (forms K, T1, T2) established in 1981. It is described in the German Industrial Standard (DIN) No. 10960, which does not only include its dimensions, volume, material and execution, but also the necessary guidelines for its use as a testing tool. Those tasting glasses that meet the standard are allowed to bear the DIN association sign, which is then placed on the foot of the glass. German wine experts are so convinced of the usefulness and effectiveness of this new tasting glass that they are even wondering whether it would be a good idea to suggest it as a replacement for the internationally standardized "ISO Glass".

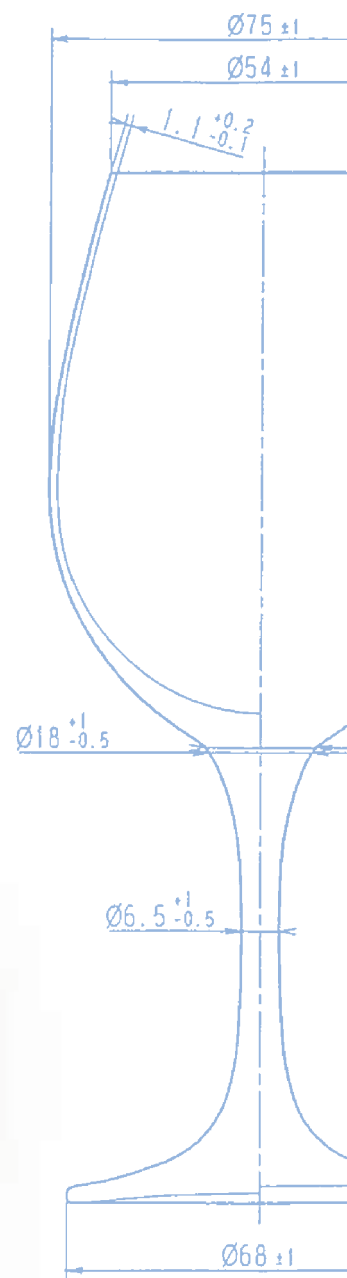

Even Simone Renth, German Wine Queen for 1999/2000, savors the full aroma that unfolds in the new "Sensus" DIN wine tasting glass from Schott Zwiesel.