

# SCHOTT SpectraLine glass harnesses

## Side emitting glass fiber optic harnesses for decorative applications

§ Side emitting glass fibers are in high demand for decorative illumination

§ These optical glass fibers are manufactured so that only some light travels through the fiber to the end, while most of the light is emitted to the sides

Special effects are generated by illuminate these fibers with

§ white light,

§ single color light,

§ changing colors or twinkle effects

There are many creative installation options

§ in a single line, e.g. for contour lighting of furniture, walls

§ as lightlines along staircases, hall ways carpets,

§ in a harness as curtain of light

§ as functional and decorative parts of chandeliers

§ etc

Our side emitting glass fibers have a small diameter of only 5 mm per single tail or light line.

They can be bent easily in a small radius for installation on site e.g. to mark the contours of a table, or a wall

Glass fiber side emitting fibers are safe and easy to maintain:

the lightsources are installed in a place remote from the area where the light is emitted through the glass fibers

§ Glass fibers are resistant to heat, temperature variations and humidity and can generate long lasting light effects in saunas, spas, or other difficult environments.



### Order Informations

Due to our production capabilities we can offer a wide range of highly customized lighting harnesses and lightguides.

We can design and assemble cable components made of different tail lengths (100 mm steps up to 5 m). 10 m when illuminated from both sides.

Even a mixture of different harness types (e.g. SpectraFlex, SpectraStream, SpectraLine, etc) within the same component can be realized (for S30 common end). These special harnesses are available on request.

Please configure and order your SpectraLine harness over E-Commerce, Schott's online order and service portal, or contact your local sales office: [www.schott.com/lightingimaging](http://www.schott.com/lightingimaging)

Specifications	Unit	SpectraLine glass harness
Fiber bundle diameter	mm (in)	3.0 (0.12)
Outer sheath diameter	mm (in)	5.0 (0.2)
Minimum bending radius	mm (in)	20 (0.79)
Max number of tails		52
Max recommended length	m (feet)	5 (15)
Common end		S30 / Excel
Sheath		Clear PVC
Operating temperature	°C (°F)	-20 ... +80 (+4 ... +176)

For installations that exceed 4-5 m, we recommend the use of lightsources on both ends.

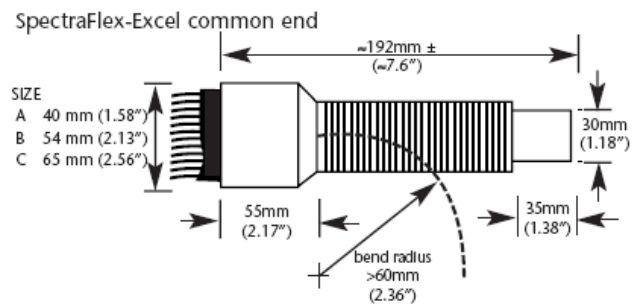
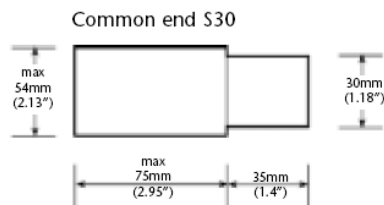

In a continuing effort to offer the best product possible, SCHOTT reserves the right to change, without notice, specifications or materials that – in SCHOTT – opinion will not alter the function of the product.

For further information please contact your local sales office:

Lighting and Imaging  
**SCHOTT AG**  
 Otto-Schott-Str. 2  
 55127 Mainz  
 Germany  
 Tel.: +49 (0) 6131/66-0  
 Fax: +49 (0) 6131/66-7846  
 lightingimaging.info@schott.com  
 www.schott.com/lightingimaging

Lighting and Imaging  
**SCHOTT Nippon K. K.**  
 7 Honshio-cho  
 Shinjuku-ku  
 Tokyo 160-00 03, Japan  
 Tel.: +81 (0) 3/53 66-2548  
 Fax: +81 (0) 3/33 58-2960  
 lightingimaging.tokyo@schott.com  
 www.schott.com/japan

Lighting and Imaging  
**SCHOTT North America, Inc.**  
 122 Charlton Street  
 Southbridge  
 MA 01550, USA  
 Tel.: +1 508 765 3235  
 Fax: +1 508 764 7361  
 LSOinfo@us.schott.com  
 www.us.schott.com/lightingimaging

**SCHOTT**  
 glass made of ideas