

Fiber Optic Light Sources and Light Guides

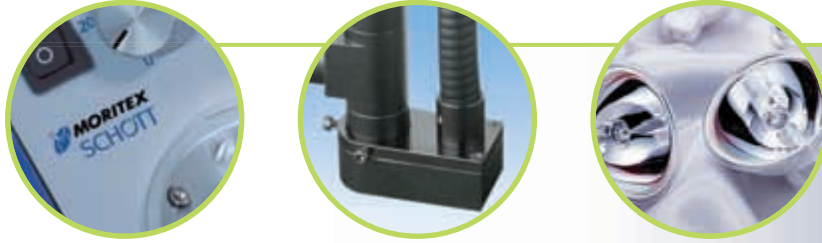

LLS2 / MHAA and MHAB Series

The MHAA / AB series Halogen light sources are compact with a robust design. These light sources are suitable for mounting. The complete product range includes: 100W, 150W and 100W NIR (1127nm). The light source can be controlled manually and through external controls, including 0-5 V analog control and parallel 8-bit digital control.

In addition, we offer the LLS2, a low-power consumption, long-life LED light source using the latest in high brightness LED technology.

These light sources can be used with fiber light guides that require less space and allow you to select from a huge range of lighting shapes and configurations.

Advantages of Fiber Optic Light Guides:

- Compact Illuminating Unit Size
- Highest Intensity Output
- Uniform Light
- All Visible Wavelengths and IR When Required
- Directional Light Control
- External Heat and Noise From Illuminated Area

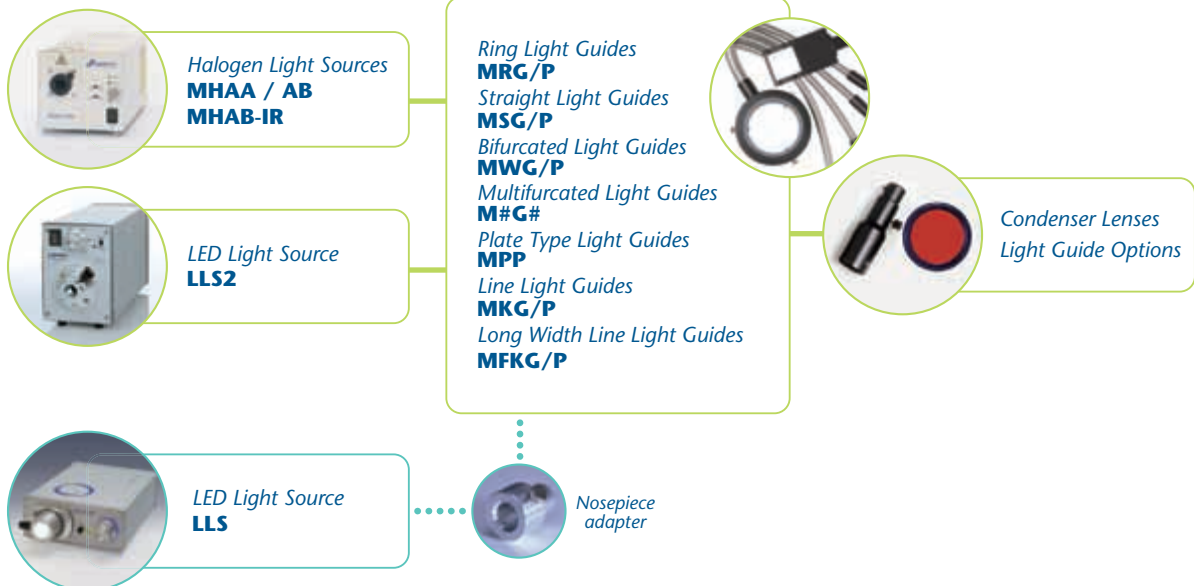



Light Sources and Available Light Guides

Light Source	Light Guide				Other Options
	Plastic		Compound Glass		
	Fiber Bundle Diameter (Light Source Side)		Standard	Heat Resistant	Internal Filter (*1)
Below 6 Dia.	6 Dia. or More				
MHAA-100W	○ *3	KA-03 *3	○	○	○
MHAB-100W-IR	×	×	×	○	×
MHAB-150W	×	×	○	○	△*2
LLS2	○ *4	KA-03 *4	○	○	—

*1 The characteristics may be changed by deterioration under the operating environment.

*2 Deterioration may be caused by use at high output.

*3 This is when the product is used at the environmental temperature of 40°C or less.

*4 This is when the product is used at the environmental temperature of 35°C or less.

- CE Marking
- RoHS Directive
- Digital & Analog Intensity Control
- 50 Wattage
- 100 Wattage
- 150 Wattage
- LED Color

NEW



LLS 2 - LED Light Source

Long-life operation, low-power consumption, and high performance LED light source for fiber optic coupling.

The movement from Halogen lamp to LED can be simple and easy with the LLS2 since its external control pin assignment is identical to the MORITEX halogen light sources.



LLS 2 - LED Light Source

LLS 2

- Low power consumption design
- Compatible with all MORITEX fiber optic light guides, including plastic
- MHAA/AB halogen light source compatible external analog and digital controls supported
- For use with light guides up to 13mm (4-10mm active diameter recommended)
- RoHS compliant and CE marked

Optional Parts

AC Cable **MC-AC100B-2.0M**

Model	LLS2
LED Color	White
Input Voltage	100-200V AC (50/60Hz)
Cooling Method	Forced air cooling
Input Voltage	AC100-120V/200-240V (50/60Hz)
LED Life	50,000hours (*1)
Light Intensity	175klx (*2)
Color Temperature	5500K
External Control	Analog input: 0-5V Digital input: 8bit
Weight	2.1kg
Security Function	Error signals: Off-temperature output and overcurrent
Operating Temperature	-10 to +45°C (humidity 20 to 90%)
Storage Temperature	-40 to +80°C (humidity 10 to 95%)
Product Code	A-4005

*1 Lumen maintenance factor 70%

*2 Measured with a 1,100mm/8mmØ light guide at 50mm distance

LLS 2 - LED Light Source

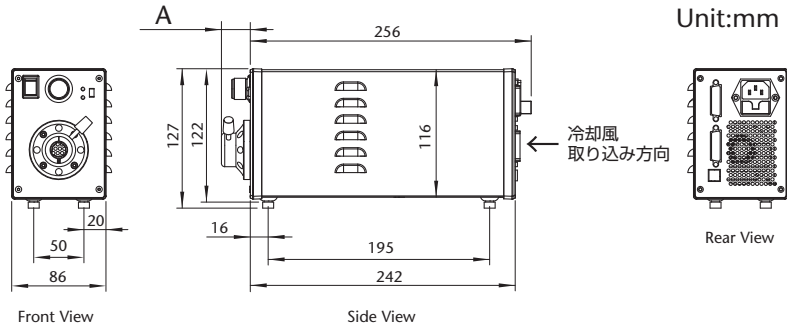

Spectral Characteristic Data

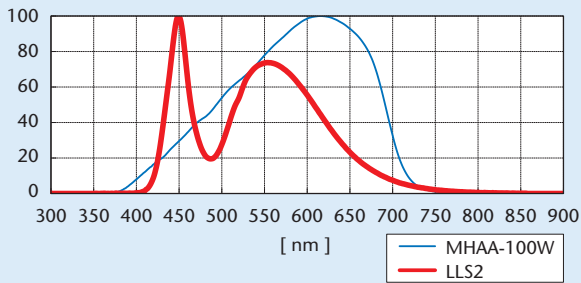

Power Consumption

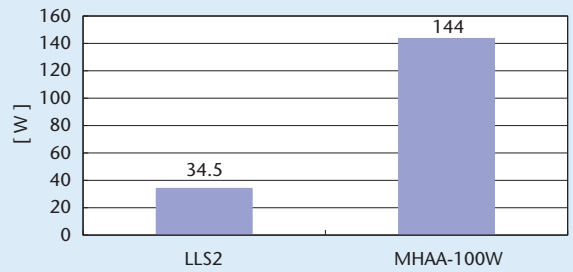

Illuminance of LLS 2 and Halogen Light Source at 50mm distance

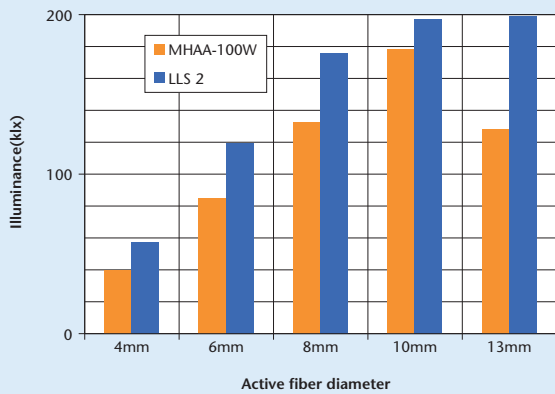

Angular Light Distribution with 10 mm Light Guide

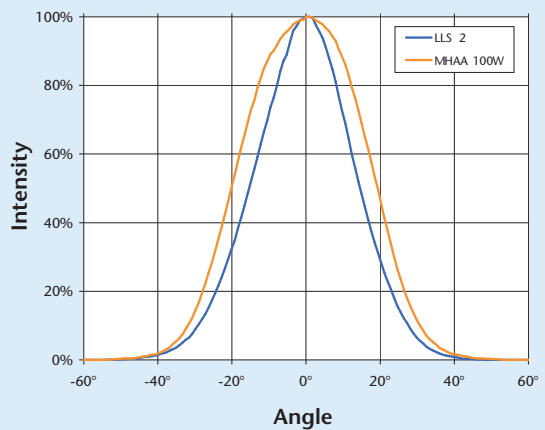



Halogen Light Sources

MHAA-100W Series



The 100W Halogen Light Source is the standard model in the Halogen Light Source Series because it exhibits excellent performance in all aspects.

- Worldwide power supply specifications (100/200V switch type)
- Compliance with CE Marking safety standards
- Environmentally friendly and in compliance with the RoHS Directive

Optional Parts

Cable with External Remote Connector	MC-EXC-02
External Remote Connector	D-SUB155
Replacement lamp	LM-100

Special Power Supply Unit Specifications (AC100V Type)

Order code	Remarks	Product Code
★ MHAA-100W-SO-100V	Built-in Shutter (Normally Open)	A-0512
★ MHAA-100W-SC-100V	Built-in Shutter (Normally Open)	A-0511
MHAA-100W-D-100V	With External 8-Bit Digital Dimmer	A-0513
★ MHAA-100W-D-SO-100V	With External Digital Dimmer and Built-In Shutter (Normally Open)	A-0515
★ MHAA-100W-D-SC-100V	With External Digital Dimmer and Built-In Shutter (Normally Open)	A-0514

★ Made-to-order products.

Halogen Light Sources

MHAA

Model	MHAA-100W	
Order Code	MHAA-100W-100V	★ MHAA-100W-200V
AC Type	100V	200V
Setting At Shipping	Input Voltage Selector: At 115 With 2.0-Meter AC Cable MC-AC 100A	Input Voltage Selector: At 230 With 2.0-Meter AC Cable MC-AC 200A
Input Voltage	AC100-120V/200-240V (50/60Hz)	
Input Voltage Switch*1	Input At AC100: Setting At 115 Input At AC200: Setting At 230	
Input Current (Typ)	2.4A (At AC 100V Input) 1.2A (At AC 200V Input)	
Compatible Lamp*2	LM-100 (12.0V,100W)	
Lamp Voltage	DC11.7V ±0.2V (Max.)	
Average of Lamp Life Time*3	1,000 Hours Nominal	
Average Illuminance*4	Approximately 30,000 Lx	
Color Temperature	3,100K	
Installation	Rubber legs placed on a flat surface	
Weight	Approximately 2.0kg	
Protection Function	Lamp Overcurrent Detection Function: Monitor output, cut off lamp power, LED (RED) on front panel ON Lamp Burn-out Detection Function: Monitor output, LED (RED) on front panel ON Internal High Temperature Detecting Function: Monitor output, cut off lamp power	
Operating Temperature and Humidity	0°C to 45°C :Linear Decrease Down to 80%RH at 31°C and 50%RH at 40°C	
Safety Standard*5	EN61010:2001 EN61000-6-2:2001/EN55011:1998,A1:1999, A2:2002	
Product Code	A-0510	A-0516

★ Made-to-order products.

*1 When the switch is set at 115V, do not apply AC 200V. Doing so may damage the power supply. When the input voltage selector is set at 230V, the device does not run on AC 100V.
 *2 Only compatible lamps can be used.
 *3 Many lamps are powered on at rated current and the time measurements until their filaments blow are normally distributed. The average time from the peak time until the survival ratio of 50% is called the average life time.
 *4 The average luminance is at 50mm from the fiber output at maximum volume when a MORITEX standard light guide (MSG4-2200S) is attached.
 *5 This is only when the voltage is -200V.
 Note: May be unable to use with plastic fibers.

MHAA-100W

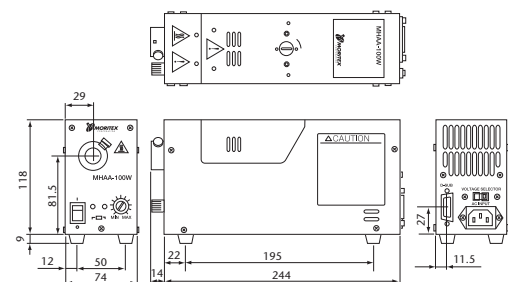

Halogen Light Sources

MHAB-150W Series



150W Halogen Light Source of dual wattage, designed for 150W but also available for 100W if a 100W lamp is attached. The intensity is the most powerful among the Halogen Light Source Series.

- High illuminance model max 80,000 Lux (2.6 times a 100W light source)
- 100W/150W Dual Wattage Lamp
- Environmentally friendly and in compliance with the RoHS Directive
- Worldwide power supply specifications

Model	MHAB-150W	
Order Code	MHAB-150W-100V	★ MHAB-150W-200V
AC Type	100V	200V
Setting At Shipping	With 2.0-Meter AC Cable MC-AC 100A	With 2.0-Meter AC Cable MC-AC 200A
Input voltage	AC100V-240V (50Hz/60Hz)	
Compatible Lamp*1	LM-150 LM-150C LM-100	
Lamp Voltage	DC 14.7V±0.2V (Max.) (LM-150 LM-150C) DC 11.7V±0.2V (Max.) (LM-100.)	
Average Lamp Life**2	50 Hours (LM-150), 500 Hours (LM-150C), and 1,000 Hours (LM-100) Nominal	
Average Illuminance**3	Approx. 80,000 Lx (LM-150), 45,000 Lx (LM-150C), and 30,000 Lx (LM-100)	
Color Temperature	3400K (LM-150) 3200K (LM-150C) 3100K (LM-100)	
Installation Method	Rubber legs placed on flat surface	
Weight	Approximately 3.2kg	
Operating Temperature and Humidity	0°C to 45°C: Linear Decrease Down to 80%RH At 31°C and 50%RH At 40°C	
Protection Function	Lamp Overcurrent Detection Function: Monitor output, cut off lamp power, LED (RED) on front panel ON Lamp Burn-out Detection Function: Monitor output, LED (RED) on front panel ON Internal High Temperature Detecting Function: Monitor output, cut off lamp power	
Safety Standard**4	EN61010:2001 EN61000-6-2:2001/EN55011:1998, A1:1999, A2:2002	
Product Code	A-0520	A-0526

★Made-to-order products.

*1 Only compatible lamps can be used.
 *2 Many lamps are powered on at rated current and the time measurements until their filaments blow are normally distributed. The average time from the peak time until the survival ratio of 50% is called the average life time.
 *3 The average luminance is at 50mm from the fiber output at maximum volume when a MORITEX standard light guide (MSG4-2200S) is attached.
 *4 This is only when the voltage is ~200V.
 Note: May be unable to use with plastic fibers.

Optional Parts

Cable with External Remote Connector	MC-EXC-02
External Remote Connector	D-SUB155
Replacement lamp	LM-100, LM-150, LM-150C

Special Power Supply Unit Specifications (AC100V Type)

Order code	Remarks	Product Code
MHAB-150W-D-100V	With External Digital Dimmer	A-0522

MHAB-150W

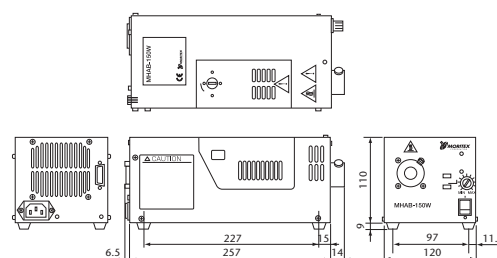



Infrared 100W Halogen Light Source

MHAB-100W-IR

Completed
Patent
Registration



Infrared 100W Halogen Light Source

MHAB-IR

- Irradiation of silicon transmission wavelength (1127nm or more)
- Radiation mechanism due to unique technology

Model	MHAB-100W-IR	
Order Code	MHAB-100W-IR-100V	★ MHAB-100W-IR-200V
AC Voltage	100V	200V
Setting At Shipping	AC cable: With MC-AC100A-2.0M	AC cable: With MC-AC200A-2.0M
Input Voltage	AC100V-240V(50Hz/60Hz)	
Compatible Lamp*1	LM-100-IR(12.0V/100W)	
Lamp Voltage	DC 10.7± 0.2V(Max.)	
Average Of Lamp Life Time*2	1,000 Hours Nominal	
Installation	Rubber Legs Placed on Flat Surface	
Weight	Approximately 3.2Kg	
Intensity Control	Manual intensity control/ External volume intensity control/ External analog intensity control	
External Dimensions	W120 ×H110 ×D257mm*3	
Product Code	A-0524	A-0527

★ Made-to-order products.

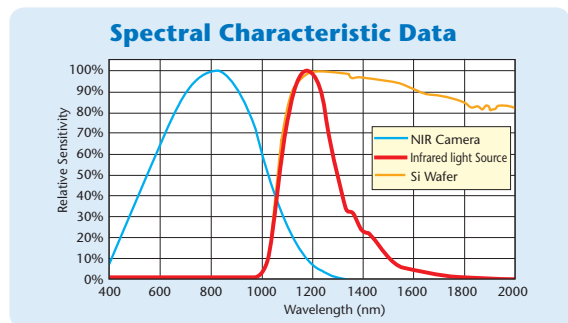

*1 Example application

*2 Many lamps are powered on at rated current and the time measurements until their filaments blow are normally distributed. The average time from the peak time until the survival ratio of 50% is called the average life time.

*3 Projections are not included.

Example Application

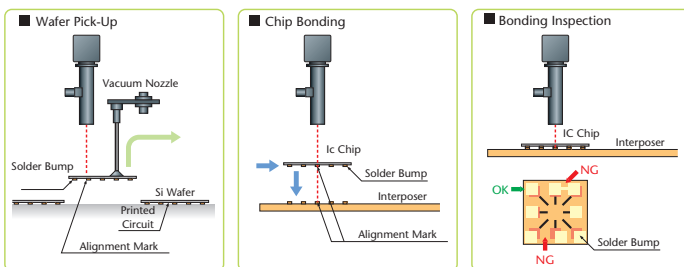

IR Coaxial Penetration Observation

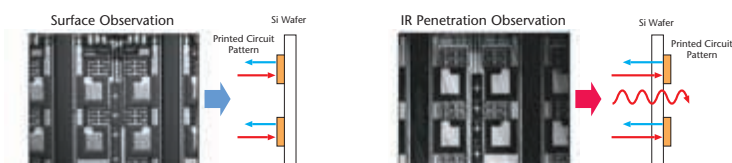

Accessories for IR Systems



Replacement Lamp

Model	LM-100-IR
Specification	IR Reflection Coating for 100W
Product Code	A-8216



Lens Series for IR System

Model	MML4-80D-IR	MML6-80D-IR	MML8-80D-IR
Specification	For IR x4x6x8		
Product Code	A-0235	A-0236	A-0237

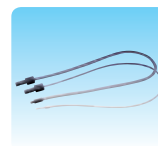

Heat Resistance Light Guide

Model	MSG4-1100S-HR
Specification	Heat Resistant
Product Code	A-0637

Note: Only heat-resistant light guides can be used.

RS-485 Communication Unit

MCGA-204D



Light controller for the batch control of MORITEX standard light sources and power supplies by RS-485 communication

- Single unit for controlling 1 channel or 2 channels
- Batch control of up to 16 channels by unit connection
- Standard light sources and power supplies connectable (Some older models not supported)

General Configuration

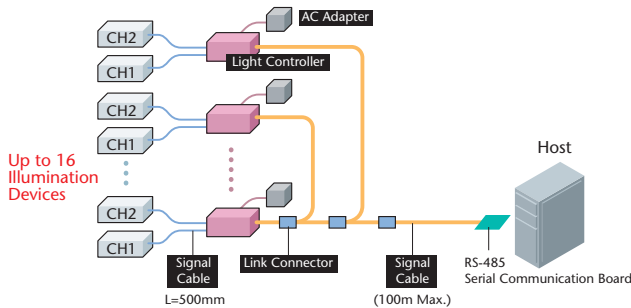

Example of Application

Halogen light source and LED power supply control by RS-485 communication

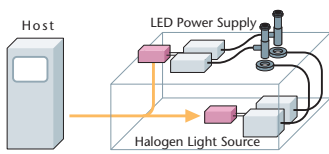

Batch control of production processes by RS-485 communication

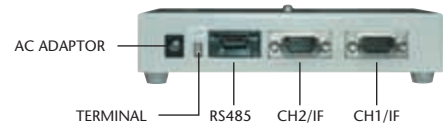
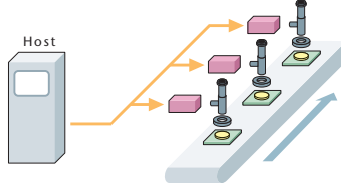

Model	Model	Product Code
MCGA-204D	RS-485 Communication Unit	A-1600
MCBB-24W-100V	ACAdapters(100V)	A-1601
MC-EXC-08	Signal Cable L=500mm	A-8230
MU-EXC-01	Communication Cable L=10m	A-9004
MU-CON-01	Link Connector (2pcs)	A-1602

Communication Specifications	
Communication Interface	RS-485
Communication System	Asynchronous, Simplex
Transmission Speed	115.2 (19.2-115.2) Kbps

Capable of connecting to MORITEX standard light sources and power supplies

MHF-V501 Series	LED Light Source
MHAA-100W Series	LL52
MHAB-150W Series	
MHAB-100W-IR	

LED Controller
MLEK Series 1ch, 2ch
MCGA units shall be necessary for MLEP Series (3-channels).

RS-485 Communication Unit

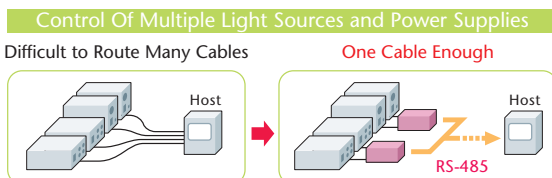
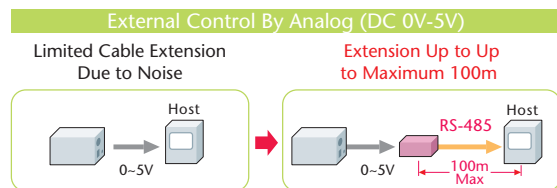
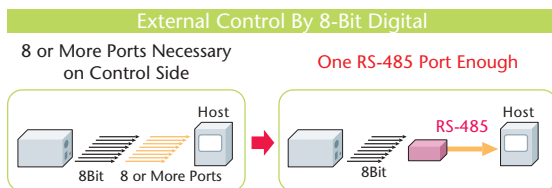

Options

Option Attachment Drawing for Halogen Light Sources

Options

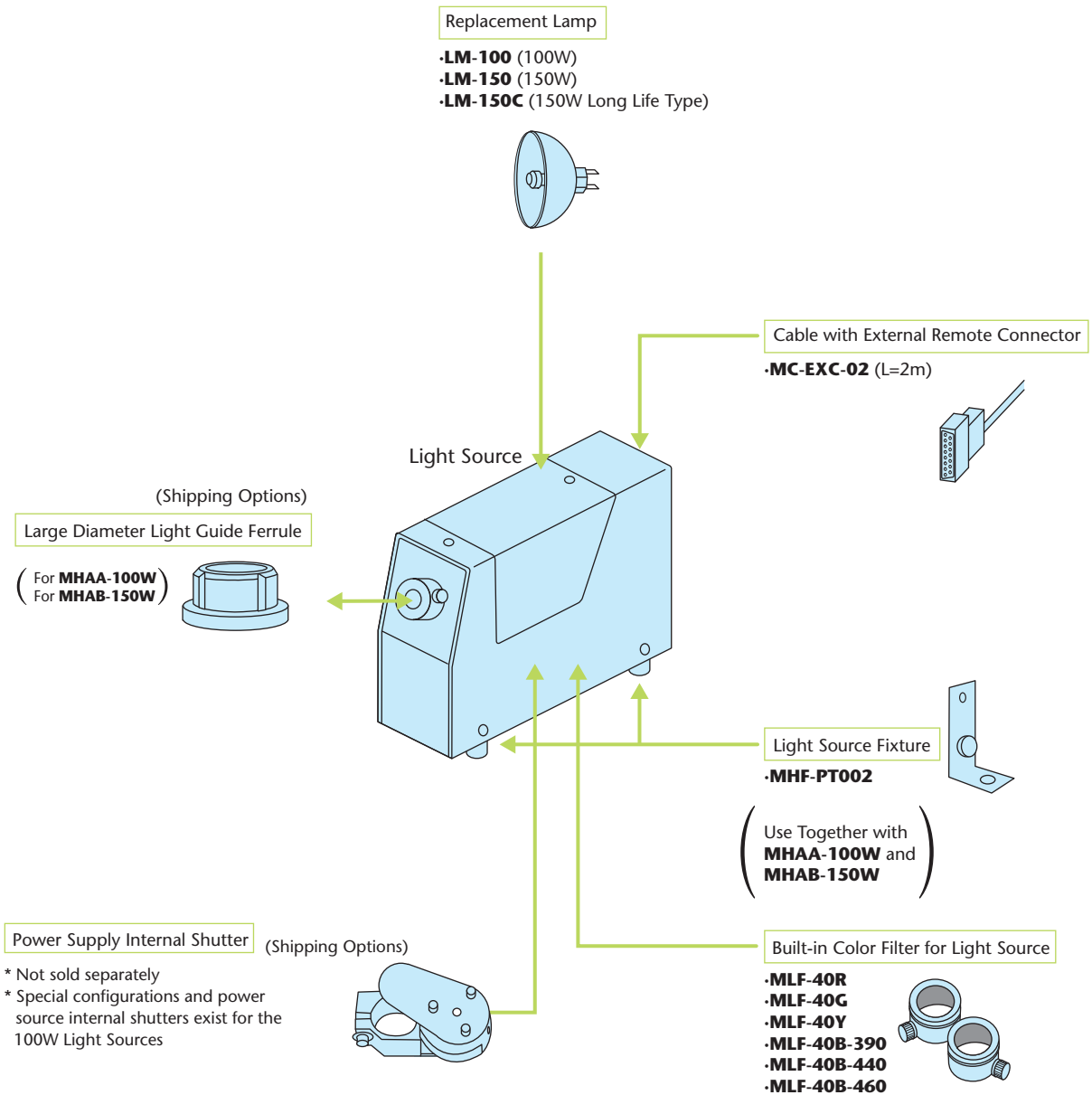

For light source compatibility, specifications and product codes of the options, see corresponding pages.

Light Source Equipment Options

Light Source Internal Shutter Product (optional at time of shipping) **Made-to-order**

- Internal type means that installation space is not necessary.
- Achieves a long life time that averages the shutter being opened and closed 50 million times
- Independent OPEN and CLOSE is possible regardless of modulation function.
- Either opening or closing for the shutter can be chosen when voltage is superimposed.

* Not sold separately as an individual item.
 * For each of the 50W, 100W, and 150W light sources there are customized specification models each with an built-in power supply.

Shutter ON/ OFF Specifications (for 50W, 100W Light Sources)

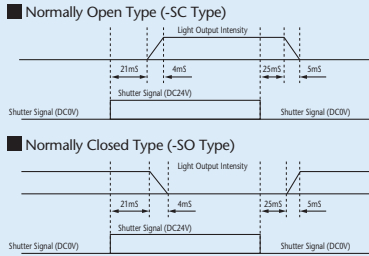

Specifications

- Operation input voltage: DC 24V 0.32A
- Shutter response speed

		50W, 100W	150W
Normally Open	Closed	25mS	33mS
	Open	30mS	
Normally Closed	Open	25mS	
	Closed	30mS	

* Response speed for a fiber with a diameter of 4mm when no protective diode exists.
 * Average life time for opening and closing of the shutter is approximately 50 million times (average for tests performed by MORITEX).
 * The OPEN and CLOSE speed of the shutter may vary slightly depending on the capabilities of the power supply being used.
 (Attachment of the model number for ordering)
 (Example) When a normal open shutter is attached to MHAA-100W-100V: MHAA-100W-SO-100V.

Light Source Internal Color Filter **Made-to-order**

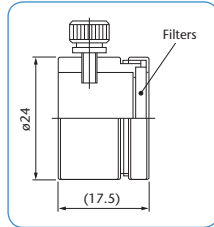
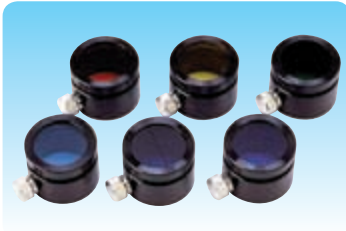

Model	MLF-40R	MLF-40G	MLF-40Y	MLF-40B-390	MLF-40B-440	MLF-40B-460
Color	Red	Green	Yellow	Bluish purple	Blue	Light blue
Peak Wavelength (nm)	600	533	480	390	440	460
Product Code	A-8247	A-8248	A-8249	A-8250	A-8251	A-8252

* Attach the filter to the light guide retainer inside the light source as if to cover it.
 * This filter cannot be used together with a built-in shutter.

Light Source Fixture

MHF-PT002 (4 pcs./set)



Model	MHF-PT002
Product Code	A-8200

*Contact MORITEX about the mounting dimensions.

Cable with External Remote Connector / External Remote Connector

Model	MC-EXC-02	D-SUB155
Product Code	A-8201	A-8202

Halogen Lamp Series : Dedicated High, Highly reliable Halogen Lamp Series



	LM-100	LM-150	LM-150C
Power Consumption	100W	150W	150W
Lamp Voltage	DC11.7V	DC14.7V	DC14.7V
Lamp Current	8.4A	10A	10A
Average Lamp Life *1	1,000hrs Nominal	50hrs Nominal	500hrs Nominal
Average Illuminance *2	Approx. 30,000	Approx. 80,000	Approx. 45,000
Color Temperature	3,100°K	3,400°K	3,200°K
Product Code	A-8213	A-8220	A-8221

*1 Many lamps are powered on at rated current and the time measurements until their filaments blow are normally distributed. The average time from the peak illumination until the survival ratio of 50% is called the average life time.
 *2 The average illuminance is measured at 50mm from the fiber end at maximum intensity when a MORITEX standard light guide (MSG4-2200S) is attached.

For Use with MHAA-100W / MHAB-150W / LLS2

External Analog Control Connection Specifications

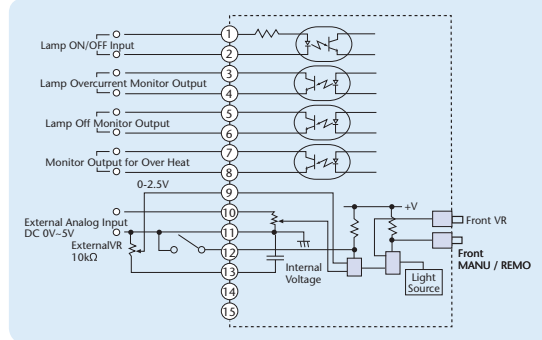
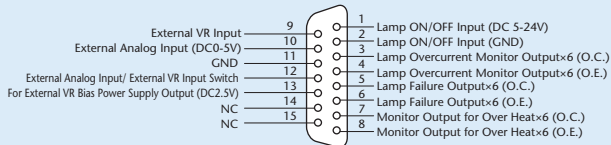

External 8-Bit Digital Control Connection Specifications

External Analog Control Connection Specifications

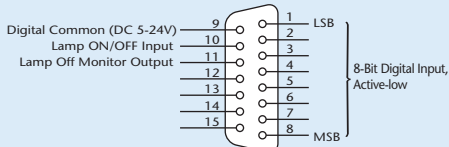

How to Use Connection Specifications and Switch Modes

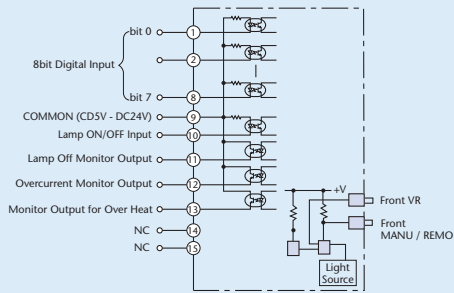

Digital Control Truth Table

LAMP ON/OFF	LAMP Monitor	BIT7	BIT6	BIT5	BIT4	BIT3	BIT2	BIT1	BIT0	LAMP Output
0	0	x	x	x	x	x	x	x	x	OFF
1	1	x	x	x	x	x	x	x	x	Lamp Burn-Out
1	0	0	0	0	0	0	0	0	0	ON (Min.)
1	0	0	0	0	0	0	0	0	1	ON
1	0	0	0	0	0	0	0	1	0	ON
1	0	0	0	0	0	0	0	1	1	ON
1	0	1	1	1	1	1	1	0	1	ON
1	0	1	1	1	1	1	1	1	0	ON
1	0	1	1	1	1	1	1	1	1	ON (Max.)

Note: X ON/ OFF Can Be Selected 0 Low 1 High

*LLS2 is equipped with 8bit modulation and "On/Off" logic pins, and capable of logic inversion.

Options

Signal Output Detection Circuit Connection Example

Signal Input Circuit Connection Example (Lamp ON/OFF Signal)

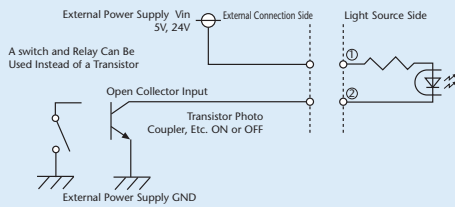

Operation	ON	OFF
With Transistor and Switch	Off	Lamp on

* The relationship between external resistance and current is as follows: Use a resistor of 1/4W power rating or greater capacity

Vin	Current
DC5V	Approximately 1~2mA
DC24V	Approximately 6~12mA

Signal Output Detection Circuit Connection Example (Lamp Burn-Out Detection Function Signal)

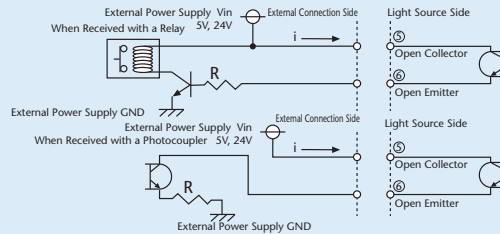

*When Signal is Outputting At i = 1mA Approximately 0.2v Between Pins No.5 and 6 At i = 5mA Approximately 1v Between Pins No.5 and 6

Signal	Between Pins No.5 and 6	Current
Lamp Normal	Not Conducted	Off
Lamp Burn-Out	Conducted	On

* The resistance and current values differ depending on parts used. Check all values well before use.

* The relationship between external resistance and current is as follows: Use a resistor of 1/4W power rating or greater capacity

Vin	R(Q)	Current I (mA)
DC5V	1~3.3k	Approx. 1to 4
DC24V	4.7~2.2k	Approx. 1to 5

Light Guides

Ring Light Guides



- Illumination from 360° produces uniform light. These light guides are optimum for CCD camera and microscope inspections.

Model	Product Code	Model	Product Code
MRP12-1500V	A-0600	MRG40-1500S	A-0607
MRP16-1500V	A-0601	MRG48-1000S	A-0608
MRP18-1500V	A-0617	MRG48-1500S	A-0609
MRP25-1500V	A-0618	MRG53-1000S	A-0610
MRP30-1500V	A-0619	MRG53-1500S	A-0611
MRG25-1500S	A-0602	MRG61-1000S	A-0612
MRG31-1000S	A-0603	MRG61-1500S	A-0613
MRG31-1500S	A-0604	MRG75-1000S	A-0614
MRP31-1000S	A-0605	MRG75-1500S	A-0615
MRP35-1500S	A-0606		

Explanation of Model Code

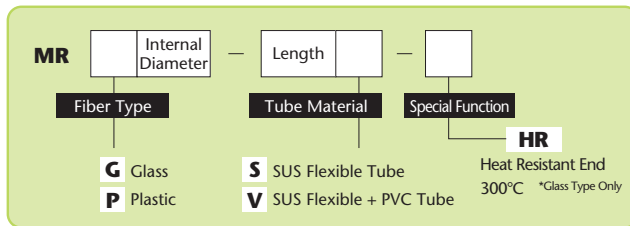

Ring Light Guides

MRG/P

MRP12-1500V

Minimum Bend R=30

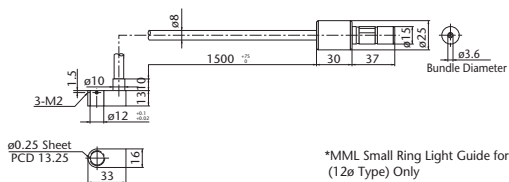

MRP16-1500V

Minimum Bend R=30

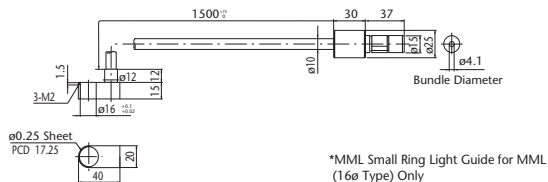

MRP18-1500V

Minimum Bend R=30

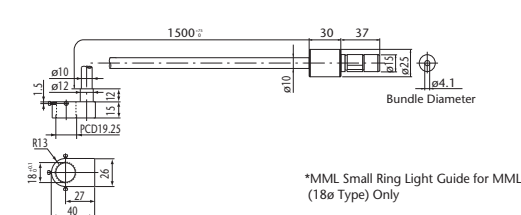

MRP25-1500V

Minimum Bend R=30

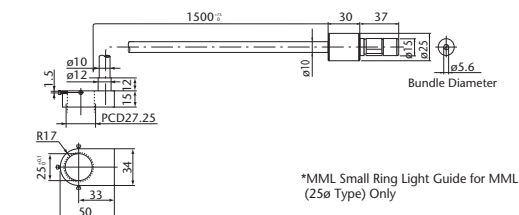

MRP30-1500V

Minimum Bend R=40
L=1500

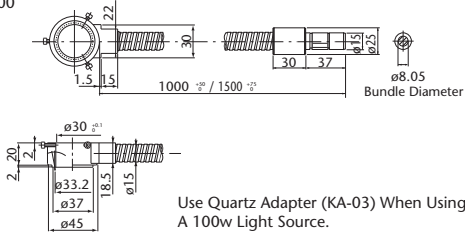

MRG25-1500S

Minimum Bend R=40

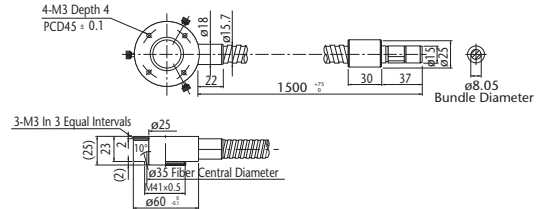

MRG31-1000S/1500S/MRP31-1000S

Minimum Bend R=40

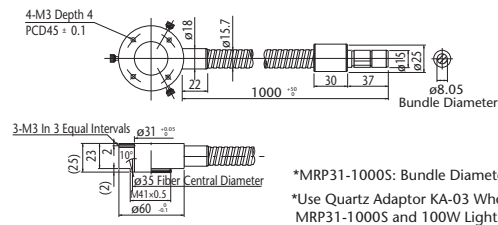

MRP35-1500S

Minimum Bend R=40

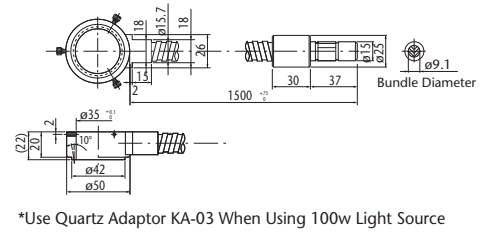

MRG40-1500S

Minimum Bend R=40

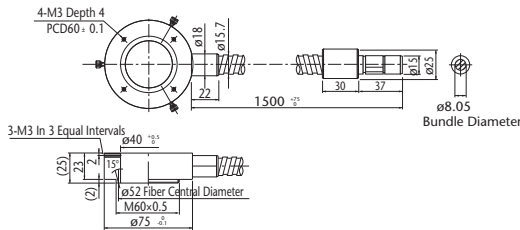

MRG48-1000S/1500S

Minimum Bend R=40

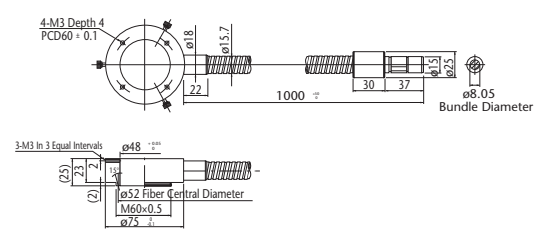

MRG53-1000S/1500S

Minimum Bend R=40

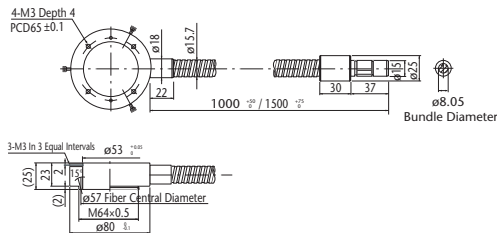

MRG61-1000S/1500S

Minimum Bend R=70

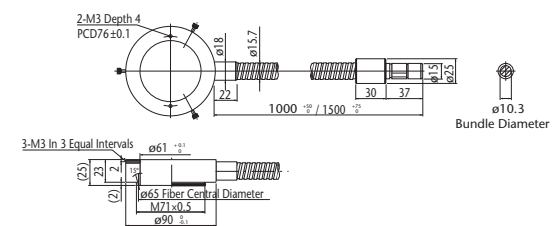

MRG75-1000S/1500S

Minimum Bend R=70

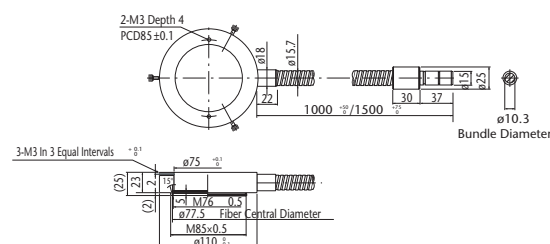

Straight Light Guides

Straight Light Guides

MSG/P

- In addition to our standard straight type light guides, many different options are available such as random assembly, heat resistant, and small diameter types.
- These light guides are ideal for spot and coaxial illumination. Select a product to suit the application.

Model	Product Code	Model	Product Code
MSG3-1100S-SD	A-0622	MSG6-2200S	A-0630
MSG4-500R	A-0623	MSG6-1100S-RM	A-0631
MSG4-1100S	A-0624	MSG6-2200S-RM	A-0632
MSP4-1100S	A-0625	MSG8-1100S	A-0633
MSG4-2200S	A-0626	MSG8-2200S	A-0634
MSG4-1100S-RM	A-0627	MSG10-1100S	A-0635
MSG4-2200S-RM	A-0628	MSG10-2200S	A-0636
MSG6-1100S	A-0629		

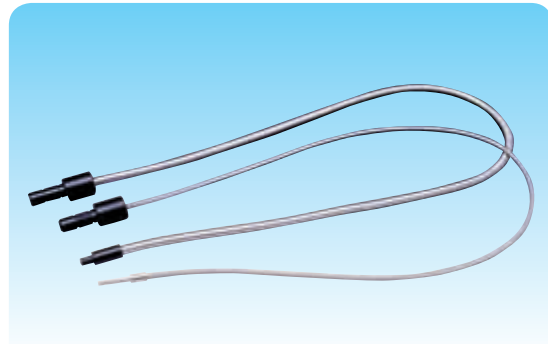

Explanation of Model Code

MS [] [] - Length [] - []

Fiber Type	Bundle Diameter	Tube Material	Special Function
G Glass	3 ø3	R Interlocking Tube	HR Heat Resistant End 300°C <small>*Glass Type Only</small>
P Plastic	4 ø4	S SUS Flexible Tube	SD Small Diameter Type
	6 ø6	V SUS Flexible + PVC Tube	RM Random Assembly
	8 ø8		
	10 ø10		

MSG3-1100S-SD

Minimum Bend R=25

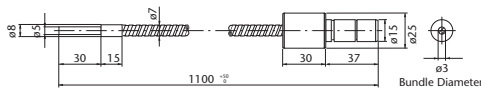

MSG4-1100S/2200S/MSP4-1100S MSG4-1100S-RM/MSG6-2200S-RM

Minimum Bend R=30

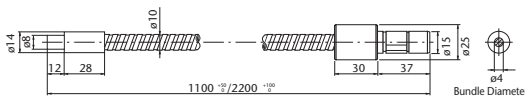

MSG8-1100S/2200S

Minimum Bend R=50

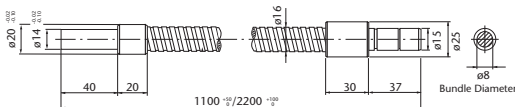

MSG4-500R (Interlocking Type)

Minimum Bend R=60

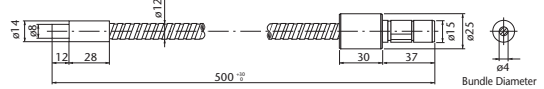

MSG6-1100S/2200S MSG6-1100S-RM/2200S-RM

Minimum Bend R=30

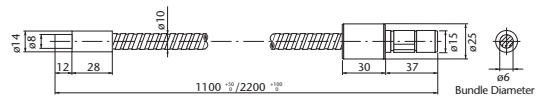

MSG10-1100S-SD/2200S

Minimum Bend R=60

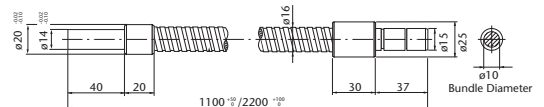

Bifurcated Light Guides

- Use these light guides for applications where lighting from two directions is needed, for example when using a microscope or CCD camera, or for pattern recognition. Coatings and tube materials can be selected to suit the purpose. Interlock type tube material allows for any necessary bending and for fixing in position SUS flexible ("goose neck") type tube material allows you to move the light guide around freely in a small space.

Model	Product Code	Model	Product Code
MWG-500R	A-0647	MWP-1000V	A-0652
MWG-L-650R	A-0648	MWG-1000SR	A-0653
MWG-1000S	A-0649	MWG7-1000S	A-0654
MWG-2000S	A-0650	MWG-1000S-SD	A-0655
MWG-1000V	A-0651		

MWG-500R (Interlocking Type)

Minimum Bend R=120

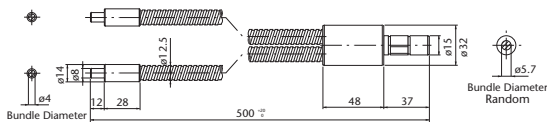

MWG-L-650R (Interlocking Type)

Minimum Bend R=60

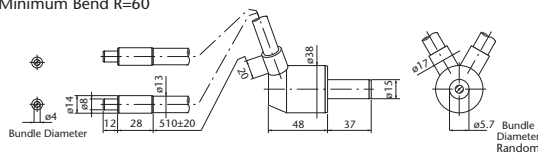

MWG-1000V/MWP-1000V

Minimum Bend R=30

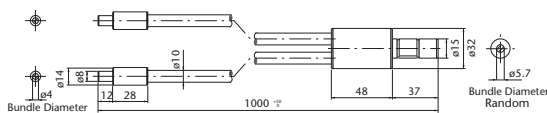

MWG7-1000S

Minimum Bend R=50

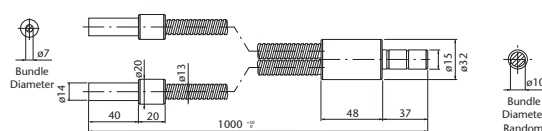

Explanation of Model Code

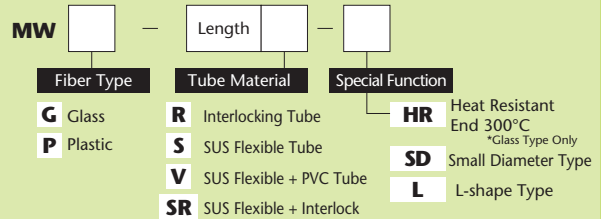

MWG-1000S/2000S

Minimum Bend R=30

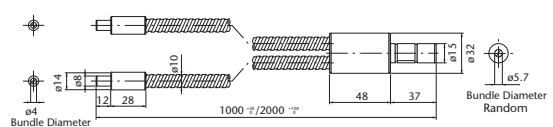

MWG-1000SR

Minimum Bend R ①=120, ②=30

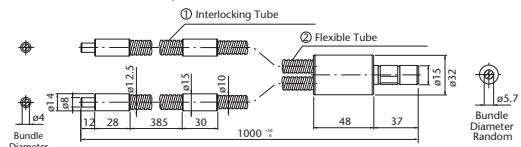

MWG-1000S-SD

Minimum Bend R=25

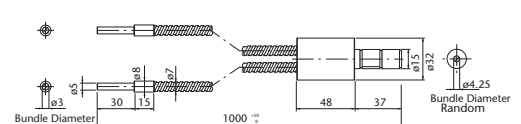

Multifurcated Light Guides



Multifurcated Light Guides

M # C #

- A 3 to 4 multifurcated light guide can be used when it is necessary to illuminate an object from many different angles, for example in the case of IC pin inspection.

Model	Product Code	Model	Product Code
M3G4-1000S	A-0663	M3G3-1000S-SD	A-0667
M3G4-2000S	A-0664	M3G3-2000S-SD	A-0668
M4G4-1000S	A-0665	M4G3-1000S-SD	A-0669
M4G4-2000S	A-0666	M4G3-2000S-SD	A-0670

Explanation of Model Code

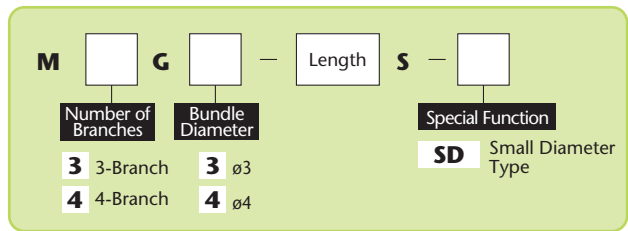

M3G4-1000S/2000S

Minimum Bend R=30

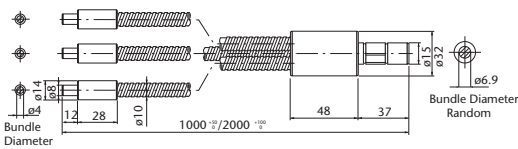

M4G4-1000S/2000S

Minimum Bend R=30

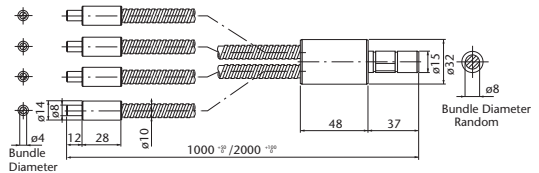

M3G3-1000S-SD/2000S-SD

Minimum Bend R=25

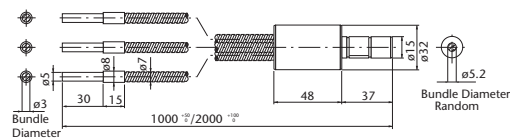

M4G3-1000S-SD/2000S-SD

Minimum Bend R=25

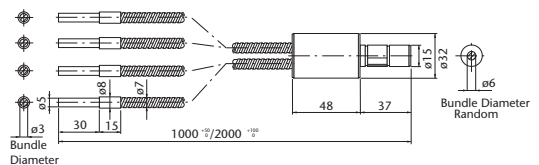
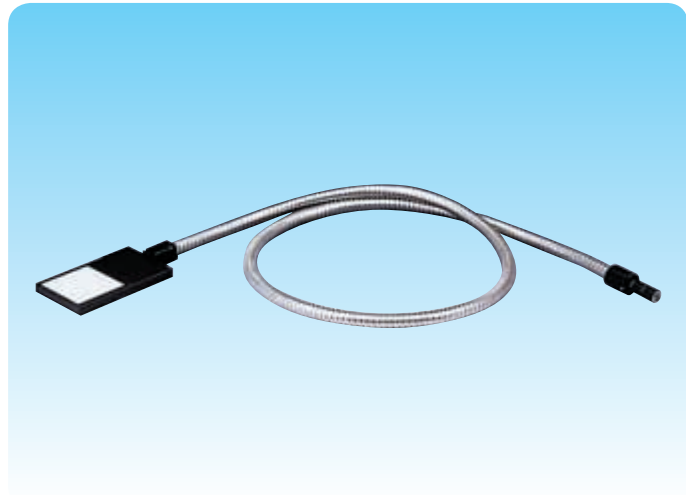

Plate Type Light Guides



- These plate type light guides do not require much space due to their slim, compact design.
- MORITEX's unique reflected light inducer allows for even and bright illumination. They can be used for multi-observation inspections that require transmitted and uniform illumination such as backlighting electronic components or semi-transparent surfaces.

Model	Product Code
MPP30-1500S-2	A-0679
MPP60-1500S-2	A-0680
MPP90-1500S-2	A-0681

Explanation of Model Code

MPP **1500S-2**

Illuminating Area

- 30** 30×30mm
- 60** 60×60mm
- 90** 90×90mm

MPP30-1500S-2

Minimum Bend R=40

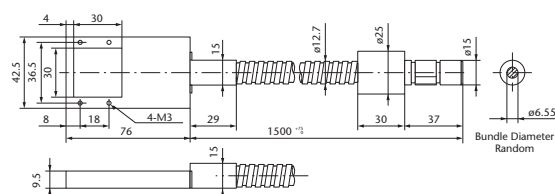

MPP60-1500S-2

Minimum Bend R=50

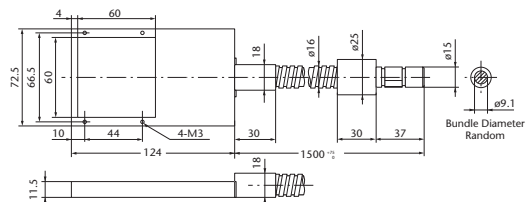

MPP90-1500S-2

Minimum Bend R=60

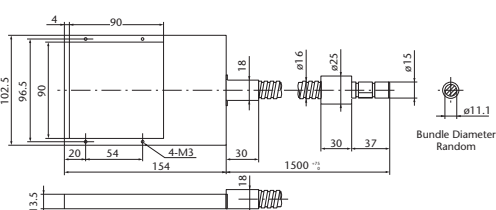

*Plastic light guides that cannot be used with 150W light sources: MPP30-1500S-2, MPP60-1500S-2, and MPP90-1500S-2. Use quartz adapter (KA-03) when using a 100W light source.

Condenser Lenses for Line Light Guides

MLK-50

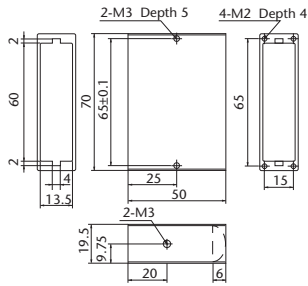

- Cylindrical focusing lens with the MKG50 light guide achieves a highly uniform beam with greater illuminance.

MLP-180

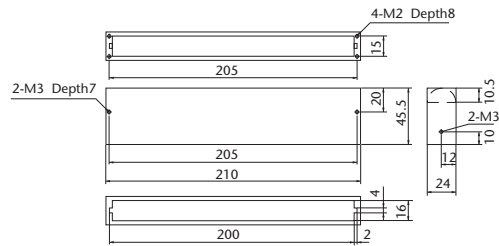

- Cylindrical focusing lens with the MKP180/ MKG180 light guides achieves a highly uniform beam with greater illuminance.

Model	Product Code
MLK-50	A-8307
MLP-180	A-8308

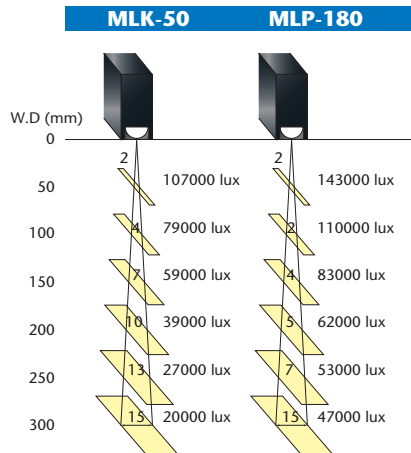

- Light source: 100W halogen light source (Volume: max)
- Fiber: MKG50-1500S for MLK-50
MKP180-1500S for MLP-180

Long Width Line Light Guides

- Line light guides with a uniform line width of 180mm can be connected to produce seamless, uniform illumination of high intensity over long widths.
- These light guides are available in multiples of 180mm from 360mm to 1440mm long. Use these long width light guides for illumination when inspecting LCD, PDP, and other glass boards and substrates or sheet products with line CCD cameras. Please note that a variable number of light sources are needed for each individual unit depending on the length.

Made-to-order

MFKG Series

Line Light Guides (glass fiber)

MFKP Series

Line Light Guides (plastic fiber)

Model	Fiber Type	Line Length(mm)	Required Quantity of Light Source	Product Code
MFKG360-2000S-SRM-L	Glass	360	2	A-0735
MFKG540-2000S-SRM-L	Glass	540	3	A-0736
MFKG720-2000S-SRM-L	Glass	720	4	A-0737
MFKG900-2000S-SRM-L	Glass	900	5	A-0738
MFKG1080-2000S-SRM-L	Glass	1080	6	A-0739
MFKG1260-2000S-SRM-L	Glass	1260	7	A-0740
MFKG1440-2000S-SRM-L	Glass	1440	8	A-0741
MFKP360-2000S-SRM-L	Plastic	360	2	A-0742
MFKP540-2000S-SRM-L	Plastic	540	3	A-0743
MFKP720-2000S-SRM-L	Plastic	720	4	A-0744
MFKP900-2000S-SRM-L	Plastic	900	5	A-0745
MFKP1080-2000S-SRM-L	Plastic	1080	6	A-0746
MFKP1260-2000S-SRM-L	Plastic	1260	7	A-0747
MFKP1440-2000S-SRM-L	Plastic	1440	8	A-0748

Explanation of Model Code

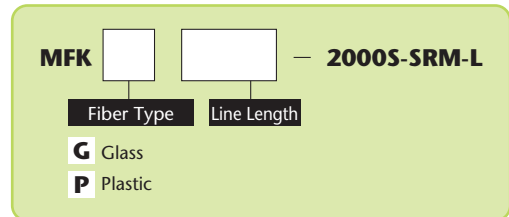

Structure of Long Width Line Light Guides

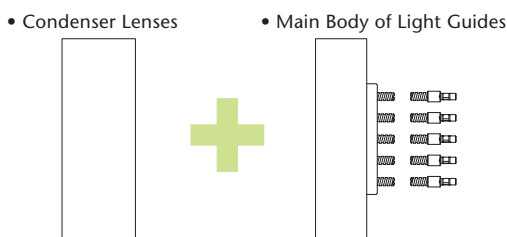

Long Width Line Light Guides are Composed of a Combination of Condenser Lenses and Line Light Guides

Light Guide

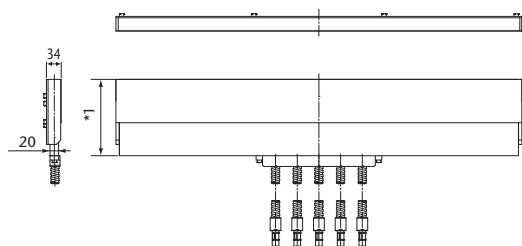

*1 Operable in Range from 159.5 to 194.5mm

Ultra-Uniform Fiber Illumination

MFKG-F1 Model Made-to-order

An ultra-uniform model for length line light guides. This model has made ultra-even possible through improvement of the falling of light intensity at the connection area, as well as through unique technology in which the light guide incidence sides give uniformity to irregularities in the light source equipment.

Usage

- Inspection of LCD glass panel inspection
- Inspection of color filters
- Inspection of sheet surface conditions

Features

- Improved uniformity through unique optical fiber manufacturing technology.
- Support for a line length of up to 3,600mm is possible.
- Ultra-uniform lighting is made possible for the condenser lens unit by using a uniquely designed optical system.
- Special optical elements that reduce light source irregularity can be installed in the light input bundle area. (Optional)
- The number of input dispersions and light source cap is specified by the customer.

(Approximate Measurements)

Standard : Maximum Band Diameter 11
Line Length possible up to 180mm x 0.5

Large Diameter Cap : Maximum Band Diameter 20
Line Length possible up to 500 mm x 0.5

Example of Production Record

MFKG1620-8000G-F1-3LD-HR

Line Length : 1,620mm

Fiber Length : 8,000mm

Model : F1

Light Source : 3 light type large diameter cap /
Special element attached /
Heat resistant specification



Explanation of Model Code

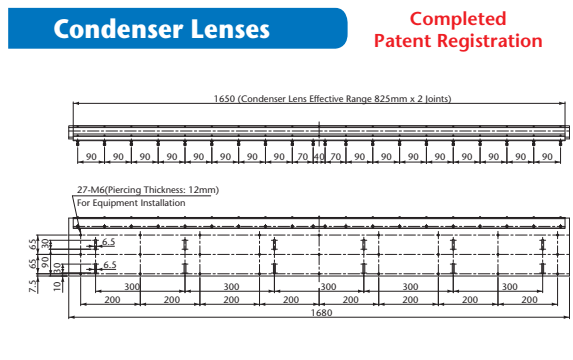
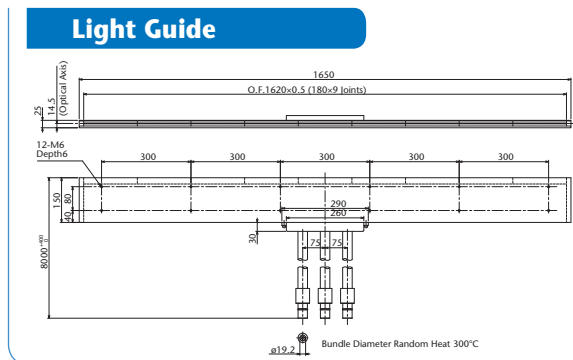
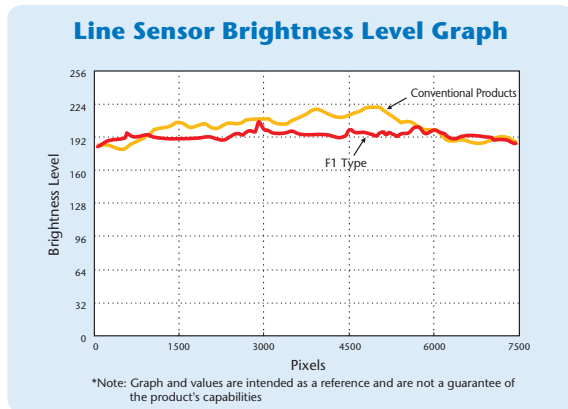
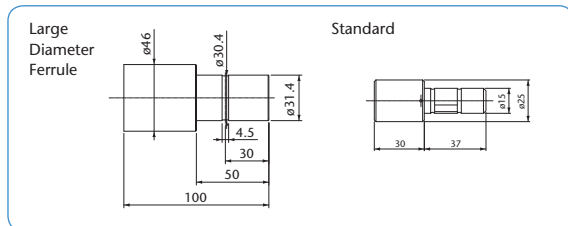
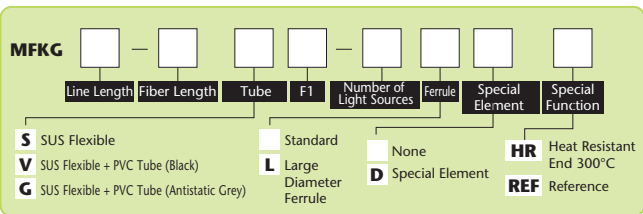

Light Guide Options

Option Attachment Drawing for Straight/ Bifurcated/ Multifurcated Light Guides

Light Guide Options

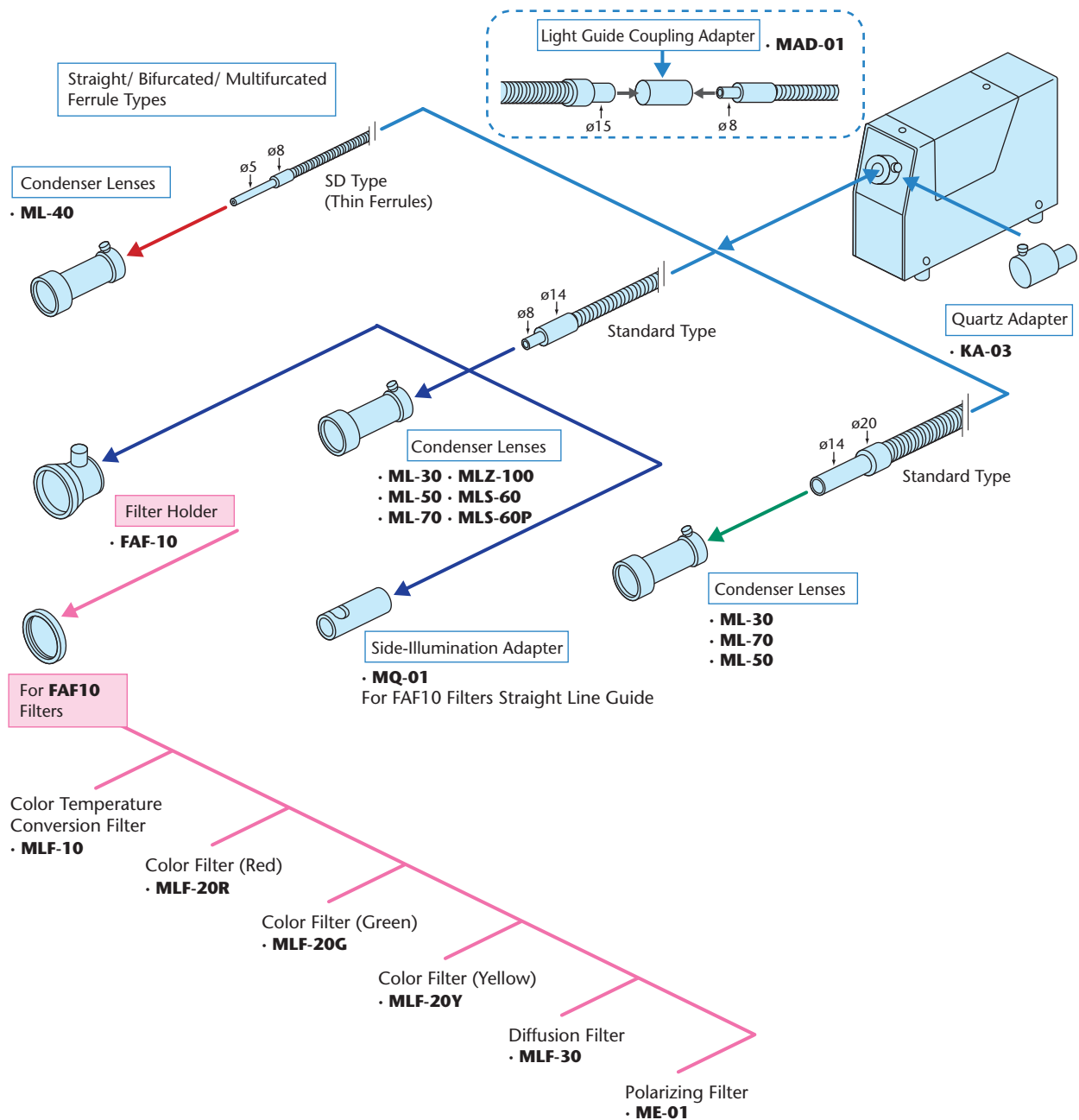

See corresponding pages for light guide compatibility, specifications, and option commodity codes.

For Straight/ Bifurcated/ Multifurcated Light Guides

Condenser Lenses

- These high performance condenser lenses were uniquely developed by MORITEX for optical fiber light guides. Through careful design and production, MORITEX ensures high quality performance at reasonable cost.



ML-30

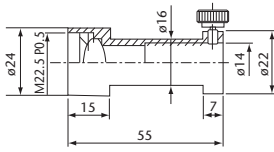

ML-40

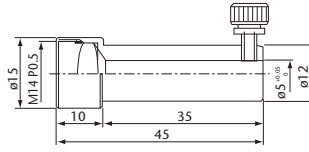

ML-50

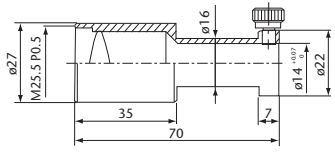

ML-70

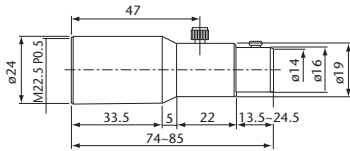

MLZ-100

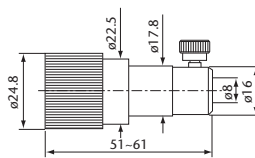

MLS-60P/MLS-60

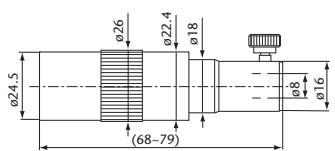

Illuminance Characteristic and Illumination Range of Condenser Lenses

Measuring Method:

- Position the illuminometer visually at the center of the illumination range (narrow or wide) and measure the illuminance. Set the illuminance of the light source to 30,000Lx for standard measurement (measurement using the standard light guide and measuring instrument).
- If the illuminance of the light source set to 30,000Lx exceeds 99,900Lx (upper limit of the measuring instrument) in standard measurement, reduce the luminous energy to the measurable range and convert the value into the range of 30,000Lx later.

Central Illuminance

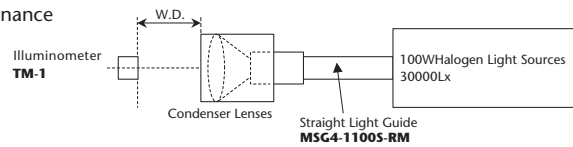

Model	Key Features	Product Code
ML-30	For straight or 2-branch light guides	A-8300
ML-40	For small diameter type (-SD)	A-8301
ML-50	Provides almost double the illuminance of the ML-30	A-8302
ML-70	For two lenses of two groups. Condenses into A uniform, comparatively small spot beam.	A-8303
MLZ-100	Uniform spot beam with each working distance. Adjustable focus function by helicoid.	A-8304
MLS-60P	Fine spot beam, focused by helicoid. Adjustable focus function by helicoid.	A-8306
MLS-60	Uniform and sharp slit beam, focused by helicoid. Adjustable focus function by helicoid.	A-8305

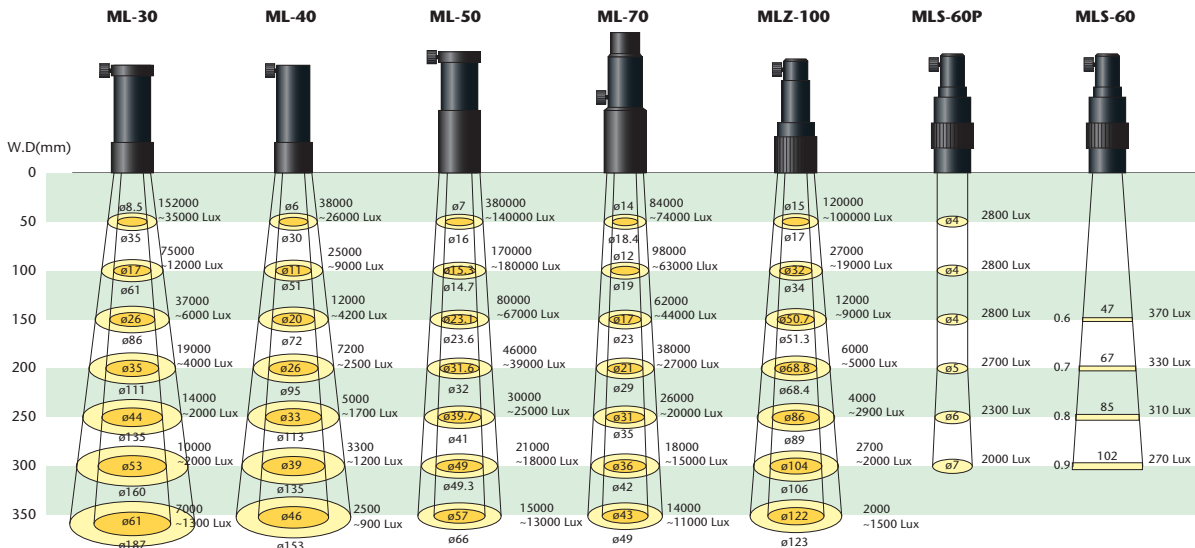

- Light source: 100W halogen light source (volume: max)
- Fiber: MSG4-1100S-RM for ML-30, ML-50, MLZ-100, and MLS-60/60P
MSG3-1100S-SD for ML-40

Filters and Adapters

A filter or adapter can be attached to the illumination port of MORITEX straight, bifurcated, or multifurcated light guide to change the color temperature of the fiber illumination, or to change the color to red, green, or yellow.

Filter Holder Made-to-order

FAF-10

- This filter holder fits a straight, bifurcated, or multifurcated light guide with irradiation port of 8.0 in the outside diameter. A color temperature conversion filter (MLF-10), color filter (MLF-20 Series of R, G, and Y colors) and diffusion filter (MLF-30) can be installed.

Model	Product Code
FAF-10	A-8321



Filters

Made-to-order

MLF-10 MLF-20 MLF-30

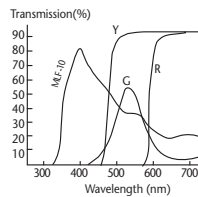

*Screw pitch M22.5x0.5

- By using a filter holder (FAF-10), the following filters can be attached:

Model	Product Name	Product Code
MLF-10	Color Temperature Conversion Filter	A-8322
MLF-20	Color Filter Set (R/G/Y)	A-8323
MLF-30	Diffusion Filter	A-8324
MLF Filter Frame	MLF Filter frame	A-8325

Polarizing Filter for Straight Light Guides

ME-01 Made-to-order

- Can be attached to either the filter holder (FAF-10) or various lenses.

Model	Product Code
ME-01	A-8340

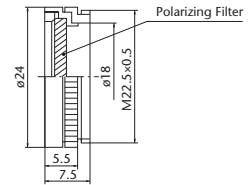

Side-Illumination Adapter

MQ-01

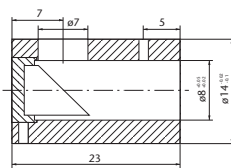

* Used to bend illumination 90° from the light guide output axis.

Model	Product Code
MQ-1	A-8346

Light Guide Coupling Adapter

MAD-01

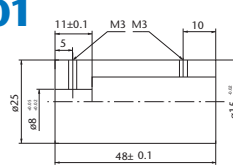

* This adapter joins the ferrules on the output side of one light guide to the input side of another.

Model	Product Code
MAD-01	A-8347

Quartz Adapter

KA-03

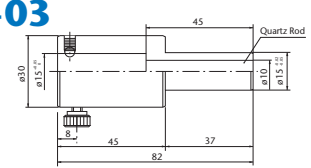

* Use this adapter when combining a 100W light source and a plastic light guide.

Model	Product Code
KA-03	A-8348

Inner Diameter Adapter Made-to-order

Model	Compatible model	Dimension A (mm)	Dimension B (mm)
MS-02 □	MRG-31	ø31	ø60
MS-03 □	MRG-48	ø48	ø75
MS-04 □	MRG-53	ø53	ø80
MS-05 □	MRG-61	ø61	ø90

* Specify the bore or internal diameter as required. The tolerance for the internal diameter is +0.1/+0.
* Coating processing not performed for the internal diameter.

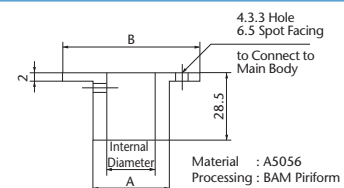

System Chart for Ring Light Guides

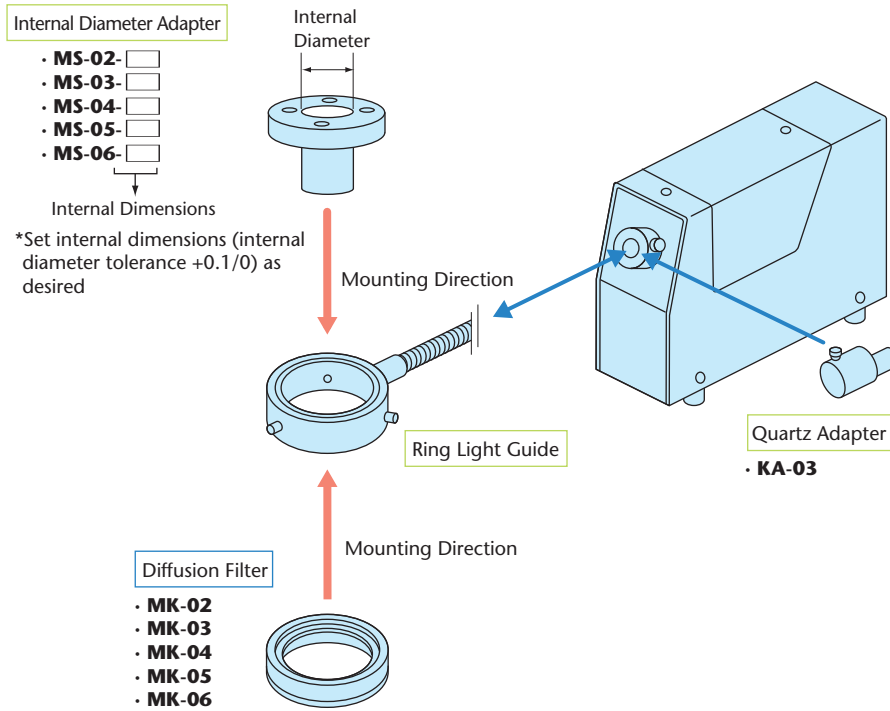

See corresponding pages for light guide compatibility, specifications, and option commodity codes.

Ring Light Guide Options

Diffusion Filter



Model	Compatible Model	External Diameter	Thickness (mm)	Product Code
MK-02	MRG-31	ø46	5.5	A-8364
MK-03	MRG-48	ø65		A-8365
MK-04	MRG-53	ø69		A-8366
MK-05	MRG-61	ø76		A-8367
MK-06	MRG-75	ø90		A-8368

Setting this filter at the light irradiation end of a ring light guide suppresses illuminance irregularity, achieving a soft illumination effect.

Light Guide Data

Mechanical Characteristics and Environment Resistance

Mechanical Characteristics

● Minimum Bend Radius

The minimum bend radius of fiber optic light guides is determined mainly by the tube's bend radius. It is also influenced by the diameter and length of the fiber optic bundle. If you bend a light guide over its limit, it cannot perform properly because transmitted light quantity decreases due to bending or disconnection of optical fiber. Note that bend radius is larger for optical fiber with a random sequence.

● Durability for Repeated Bending

Although durability of optical fiber for repeated bending varies depending on types, it is not very good overall. Optical fiber breaks or deteriorates because of twisting, friction with other optical fiber, and friction within tubing (coating for a fiber optic bundle). When this happens, transmitted light quantity reduces and a light guide cannot perform sufficiently. Durability for repeated bending is even lower for optical fiber with a random sequence. If more durability is required, use a flexible light guide (special order) with a different internal structure and special coating agent.

Environment Resistance

● Heat Resistance

The normal heat resistance ranges for raw plastic fiber, multi-component glass fiber, and quartz fiber are 70, 430°C (except oiling), and 1,000°C (except coating) respectively. Upper limit temperature for light guides ends differs according to the heat resistance of adhesives and coating materials used to protect optical fiber. Upper limit temperature for raw plastic fiber, multi-component glass fiber, and quartz fiber are 70°C, 200°C, and 200°C respectively.

If higher heat resistance is required, please use heat-resistant line guides (special order, 300°C for multi-component glass fiber and quartz fiber). If even higher heat resistance is required, quartz fiber light guides that are resistant to 500°C can be manufactured.

Life of raw optical fiber varies according to temperature that it is used at, and the amount and time of change in temperature. Please contact us before using light guides in special conditions.

Heat Resistance

Optical Fiber	Heat Resistance of Raw Fiber (°C)	End Heat Resistances of Standard Products (°C)	End Heat Resistance of Heat-Resistant Products (°C)
Plastic	70	70	—
Multi-Component Glass	430 (Except Oiling)	200	300
Quartz	1,000 or More (Except Coating)	200	300, 500

Transmittance Rate and Luminosity Distribution Characteristics

Optical Fiber Data

	Compound Glass	Plastic	Quartz
Fiber Diameter	50 μ m	250 μ m 500 μ m 750 μ m 1000 μ m 2000 μ m	208 μ m(Many Others)
Core Diameter	47.2 μ m	(3-5 μ m Less Than Fiber Diameter)	200 μ m(Many Others)
Entrance Angle	Approx. 64°	Approx. 60°	Approx. 25°
Upper Temperature Limit for Light Guide Ends*1	Standard Type 200°C Special Order 300°C	Standard Type 70°C	Standard Type 200°C Special Order 500°C
Durability	△	○	×
Heat Resistance	○	×	○
Transmittance*2 (Visible Light for Short Distance)	△	△	○
Values	○	○	×

○Excellent △Problems in certain conditions ×Not recommended
For reference only. Consult MORITEX for details
*1 Data of a bundle (not element wire data)
*2 Transmission at 10m or less

Distribution Characteristics of Light Guide and Halogen Light Source

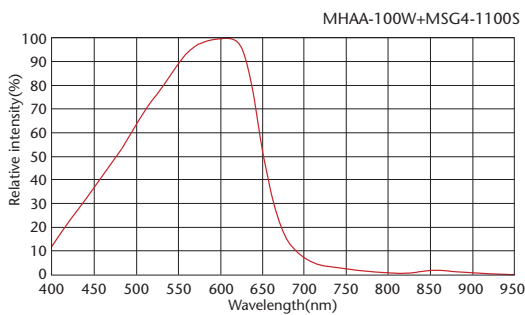

Luminance Distribution of Ring Light Guide

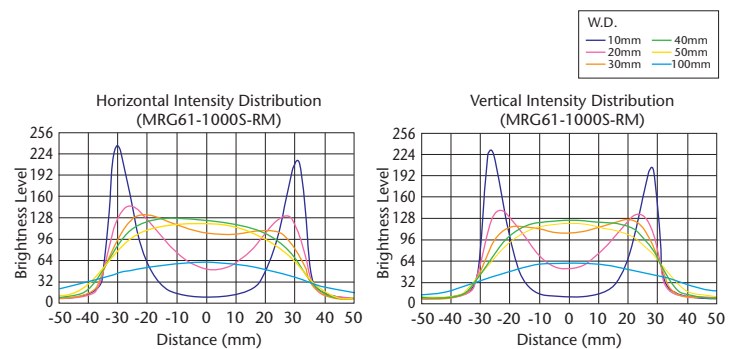

Length and Transmission of Light Guide

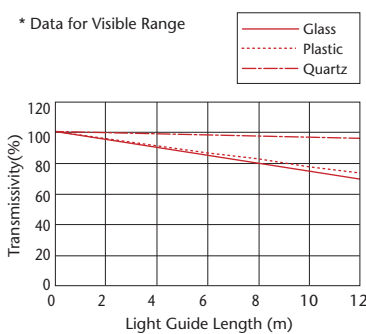

Luminance Distribution of Line Light Guide

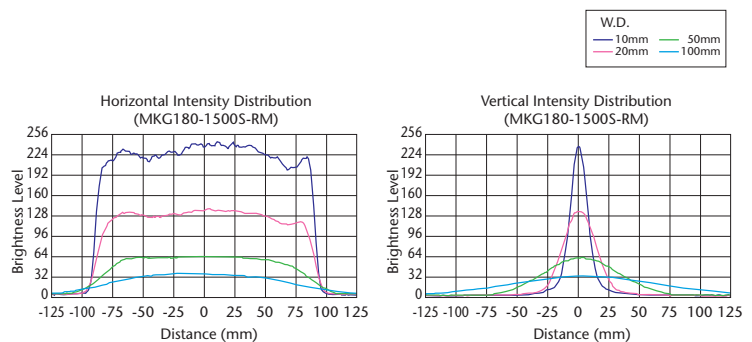

Spectral Transmission of Different Light Guides

