

SCHOTT Slim LightBar System

High-quality multipoint fittings for fiber optic display case lighting

Only 20 mm in diameter, this slender yet powerful lightbar from SCHOTT can be mounted virtually anywhere — without obstructing the view. Benefits include:

- **Conservation of display contents.** With no heat—and excellent UV protection—Slim LightBars protect artwork, exhibits and priceless artifacts from fading.
- **Highly effective lighting.** Slim LightBars from SCHOTT offer a slender 20 mm diameter that provides even lighting without shadows. Effective for close-up lighting, Slim LightBars are ideal for retail applications where they add extra “sparkle” to jewelry, watches, cut glass and other products. Slim LightBars are unobtrusive and do not distract from the exhibited objects.
- **Low maintenance.** Because the light source for the Slim LightBar is situated in a remote location—and electrically isolated from the display case itself—displays remain undisturbed and protected from dust during lamp changes and routine cleaning.
- **Easy installation.** Slim LightBars are easy to install in confined spaces—either vertically or horizontally—since they can be disconnected from their harnesses.
- **Flexibility and cost effectiveness.** Because a single light source can illuminate many Slim LightBars, this SCHOTT solution ensures outstanding cost effectiveness and design flexibility.



Ordering Information

Please configure and order your Slim LightBar over E-Commerce, Schott's online order and service portal, or contact your local sales office: www.schott.com/lightingimaging

Specifications

Slim LightBar™ diameter	mm (in)	20 (0.787)
Slim LightBar™ minimum length	mm (in)	200 (7.87)
Slim LightBar™ maximum length	mm (in)	1700 (66.93)
pitch between light points	mm (in)	20 (0.787)
material		Aluminum
color		matt black, matt silver
operating temperature	°C (°F)	-20... +80 (+4... +176)

Ordering Information

	Slim LightBar	length mm (in)	Order No.		tail size	Max. number of Slim Lightbars – S30 common end
			matt black	matt silver		
Slim LightBar A	200 - 500	(7.87-19.69)	1121489	1121596	Size 24	16
Slim LightBar B	501 - 800	(19.72-31.5)	1121490	1121597	Size 36	10
Slim LightBar C	801 - 1000	(31.54-39.37)	1121491	1121598	2XS24	8
Slim LightBar D	1001 - 1400	(39.41-55.12)	1121522	1121623	2XS36	5
Slim LightBar E	1401 - 1700	(55.16-66.93)	1121523	1121624	2XS36	5
Slim LightBar F	801 - 1000	(31.54-39.37)	1121524	1121627	Size 36	10

™Slim LightBar is a trademark SCHOTT AG.

For more informations about the harness sizes 24 and 36 we refer to the datasheets SpectraFlex® glass harnesses and SpectraFlex® Excel glass harnesses

Light output of a Slim LightBar with different light sources

		600 lux @ 250 mm distance from a 1000 mm Slim LightBar with 1500 mm tail			
LightBars per light source		1	2	4	6
150 SEF	4200K*	1	1	0.8	0.65
70 SEF	4200K*	0.5	0.5	0.4	0.35
100 SLH	100 W	0.5	0.5	0.4	0.35
100 SLH	71 W	0.35	0.35	0.3	0.25
100 SLH	50 W	0.15	0.15	0.1	0.098

*Using SpectraNova 70SES & 150SES 4200k models provide a 10% increase in light output.

In a continuing effort to offer the best product possible, SCHOTT reserves the right to change, without notice, specifications or materials that – in SCHOTT – opinion will not alter the function of the product.

For further information please contact your local sales office:

Lighting and Imaging
SCHOTT AG
 Otto-Schott-Str. 2
 55127 Mainz
 Germany
 Tel.: +49 (0) 6131/66-0
 Fax: +49 (0) 6131/66-7846
 lightingimaging.info@schott.com
 www.schott.com/lightingimaging

Lighting and Imaging
SCHOTT Nippon K. K.
 7 Honshio-cho
 Shinjuku-ku
 Tokyo 160-00 03, Japan
 Tel.: +81 (0) 3/53 66-2548
 Fax: +81 (0) 3/33 58-2960
 lightingimaging.tokyo@schott.com
 www.schott.com/japan

Lighting and Imaging
SCHOTT North America, Inc.
 122 Charlton Street
 Southbridge
 MA 01550, USA
 Tel.: +1 508 765 3235
 Fax: +1 508 764 7361
 LSOinfo@us.schott.com
 www.us.schott.com/lightingimaging

Harness end ferrules

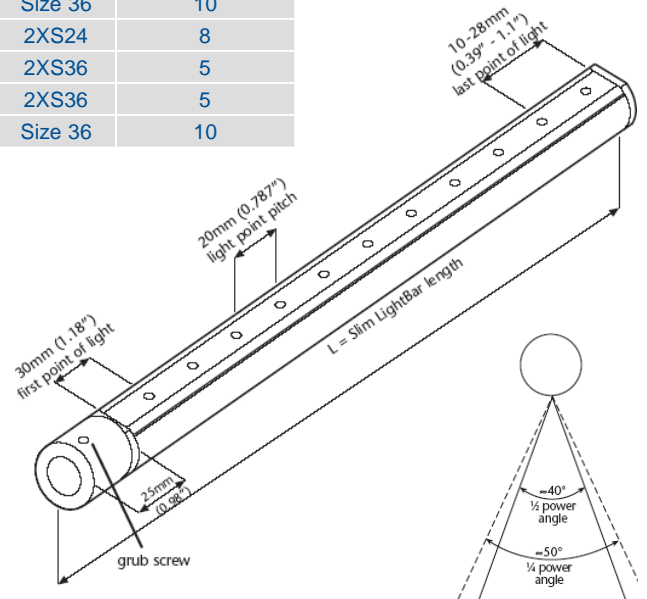
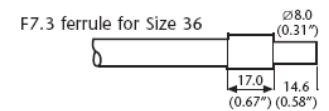
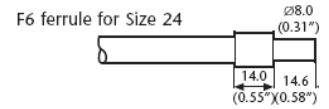
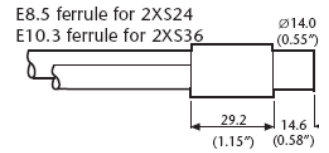

Harness tail bending clearance

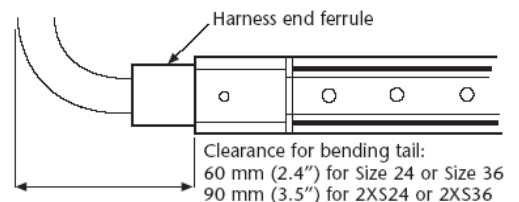

SCHOTT
 glass made of ideas